

THIS DOCUMENT CONTAINS PROPRIETARY INFORMATION AND IS THE PROPERTY OF WILDER TECHNOLOGIES. THIS INFORMATION SHALL NOT BE REPRODUCED, TRANSFERRED TO OTHER DOCUMENTS, DISCLOSED TO OTHERS FOR MANUFACTURING OR ANY OTHER PURPOSE WITHOUT WRITTEN PERMISSION FROM WILDER TECHNOLOGIES.

REVISIONS				
REV	AUTH	DESCRIPTION	APVD DATE	CHK DATE
A	XXXX	INITIAL RELEASE	TD	9/6/2011
B	XXXX	COAXIAL CABLES WERE 6-INCH FEMALE	TD	11/15/2011
C	XXXX	CHANGED TYPE OF PROTECTIVE CAP	TD	9/27/2013

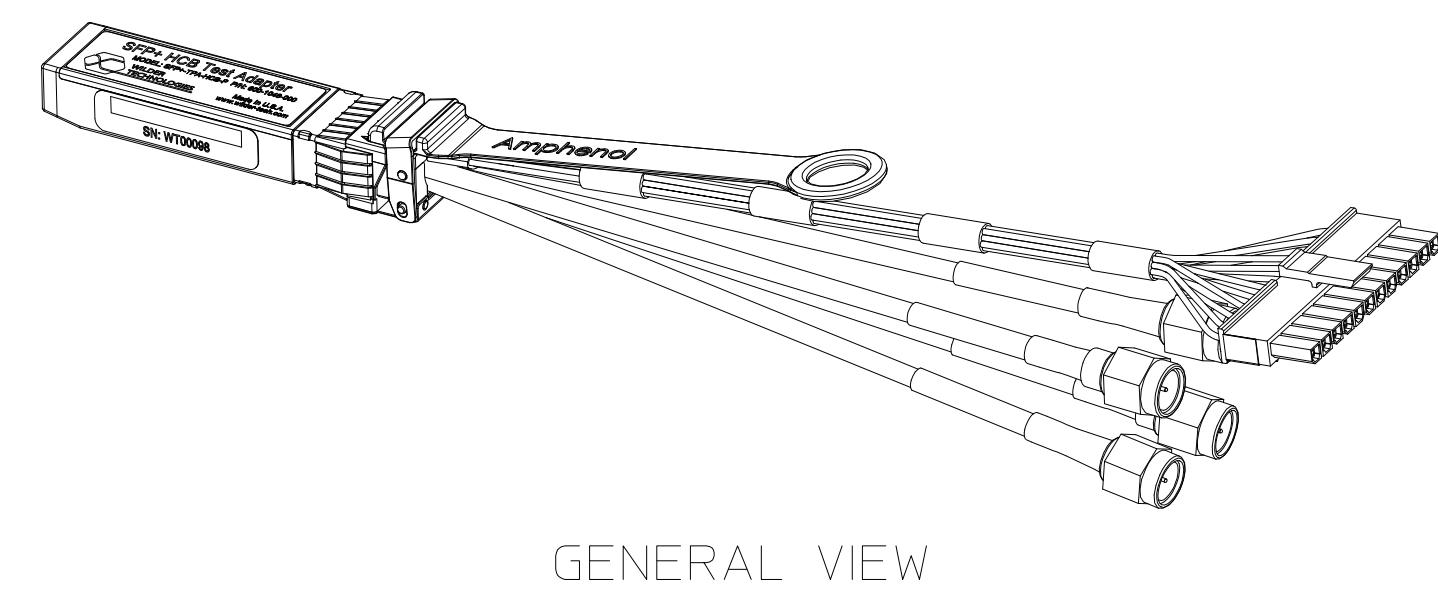
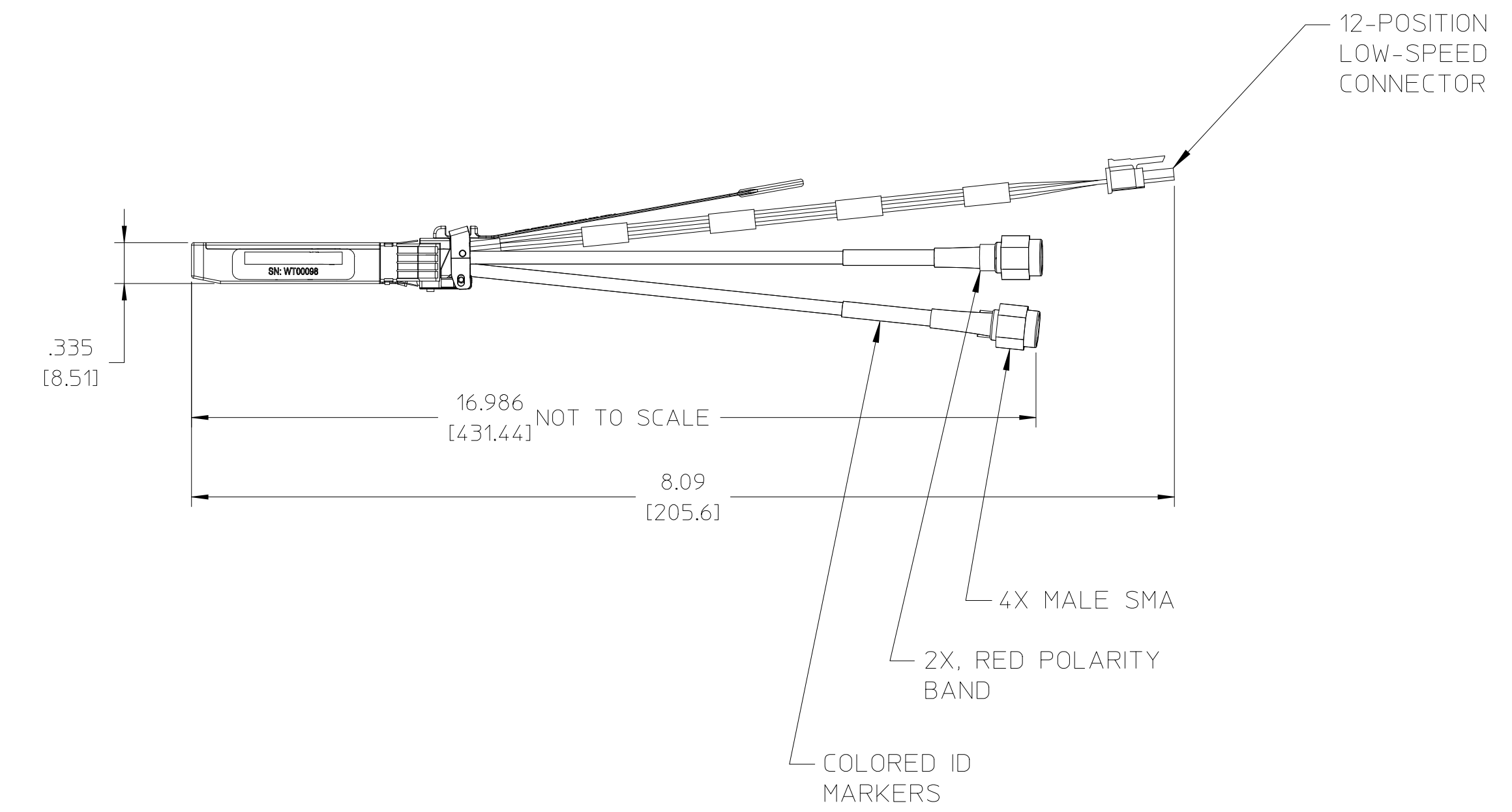
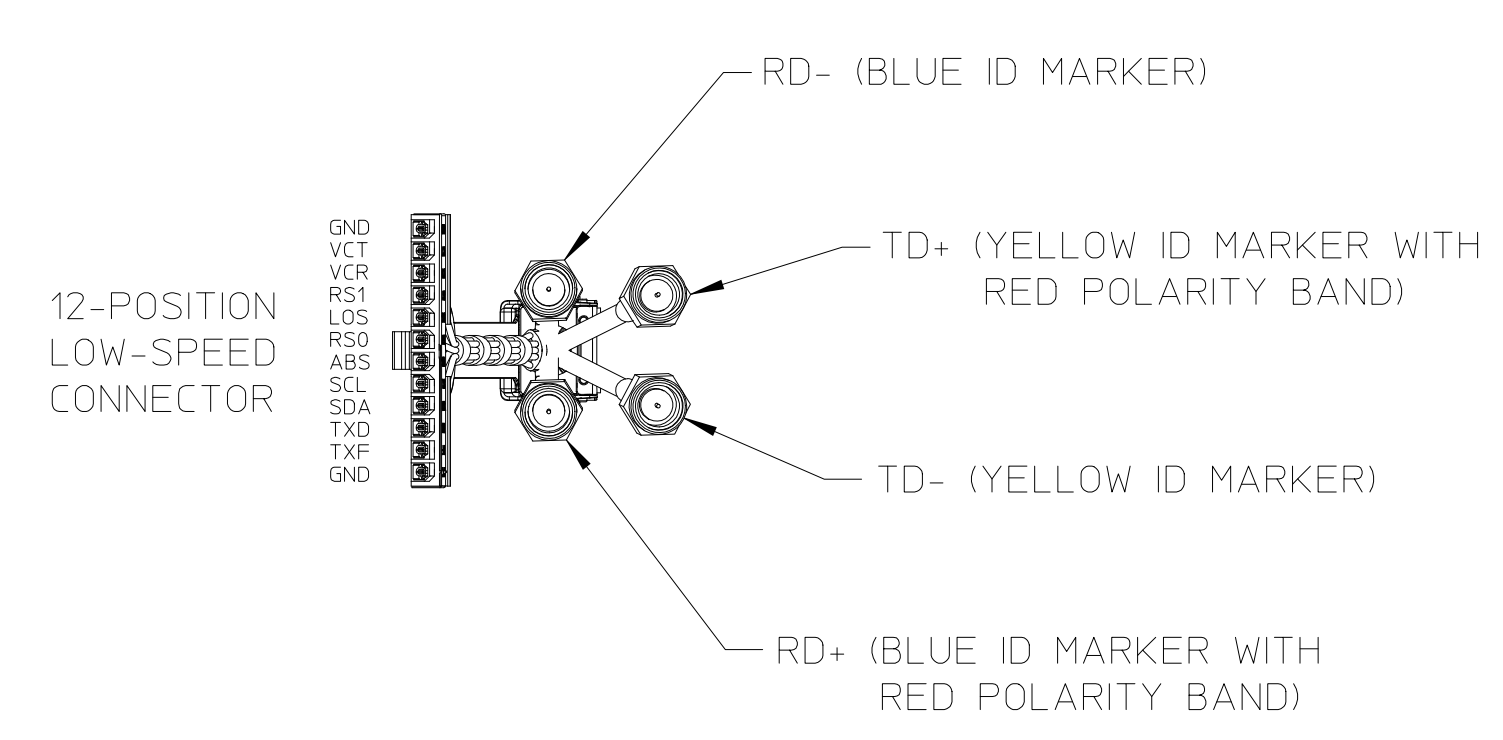
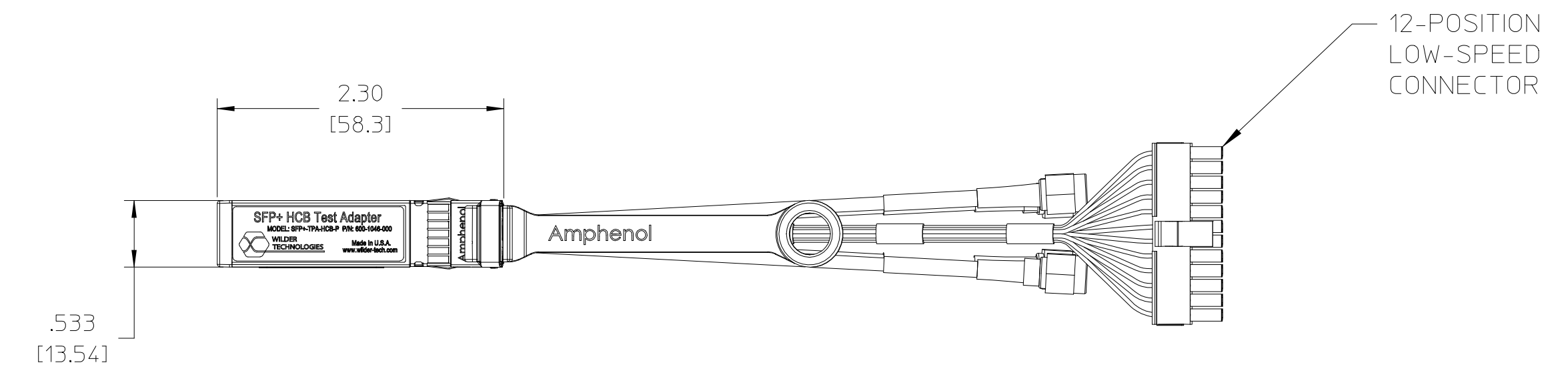

- NOTE: UNLESS OTHERWISE SPECIFIED
1. INTERPRET DIMENSIONS AND TOLERANCES PER ANSI Y14.5.
  2. REFER TO THE USERS MANUAL FOR DETAILED MECHANICAL AND ELECTRICAL SPECIFICATIONS.

UNLESS OTHERWISE SPECIFIED DIMENSIONS ARE INCHES [METRIC]		6101A East, 18th St, Vancouver, WA 98661 Tel: 360-859-3041 Fax: 360-859-3105 www.wilder-tech.com	
.XXX + .005 + .027 +	.XX + .01 + .25 +	.X + .12 + .3 +	ANGLE + 1° 1°
MATERIAL:	N/A	APPROVED BY:	T. DELUCCO
FINISH:	N/A	CHECKED BY:	DATE: 9/6/2011
DESCRIPTION:		DATE:	
CUSTOMER REFERENCE DWG.		DATE:	
ASSEMBLY, FINAL.		DATE:	
SFP+ PLUG (SFP+-TPA-HCB-P)		DATE:	
SIZE:	D	PART NUMBER:	600-1046-000
SCALE:	1:1	DO NOT SCALE DRAWING	SHEET 3 OF 3