

THIS DOCUMENT CONTAINS PROPRIETARY INFORMATION AND IS THE PROPERTY OF WILDER TECHNOLOGIES. THIS INFORMATION SHALL NOT BE REPRODUCED, TRANSFERRED TO OTHER DOCUMENTS, DISCLOSED TO OTHERS FOR MANUFACTURING OR ANY OTHER PURPOSE WITHOUT WRITTEN PERMISSION FROM WILDER TECHNOLOGIES.

REVISIONS				
REV	AUTH	DESCRIPTION	APVD DATE	CHK DATE
A	ECNXXXX	INITIAL RELEASE		7/29/16

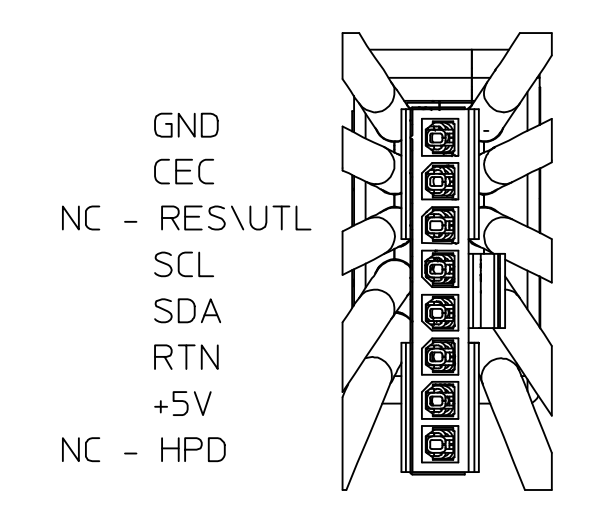

(LOW SPEED CABLE INTERFACE)
DETAIL B
 SCALE 2:1

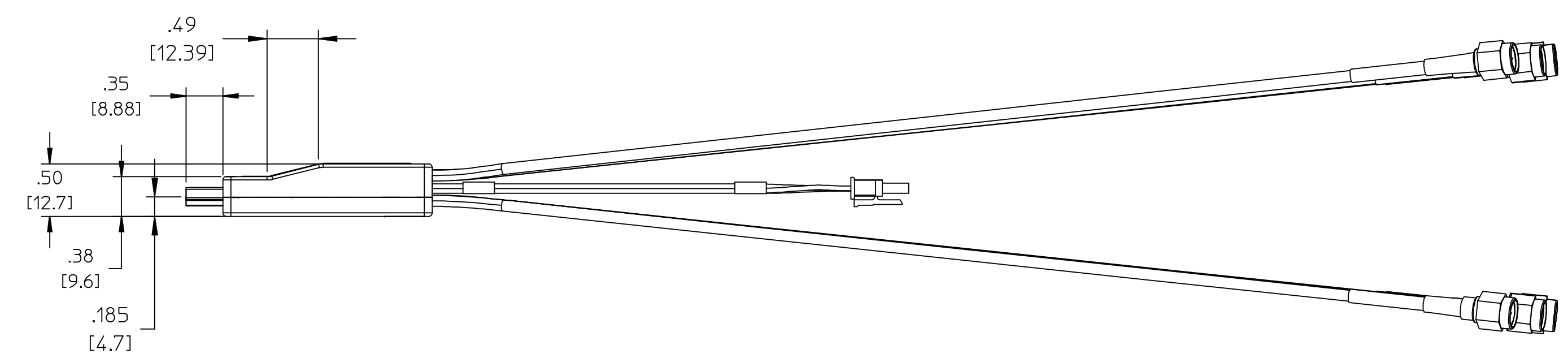
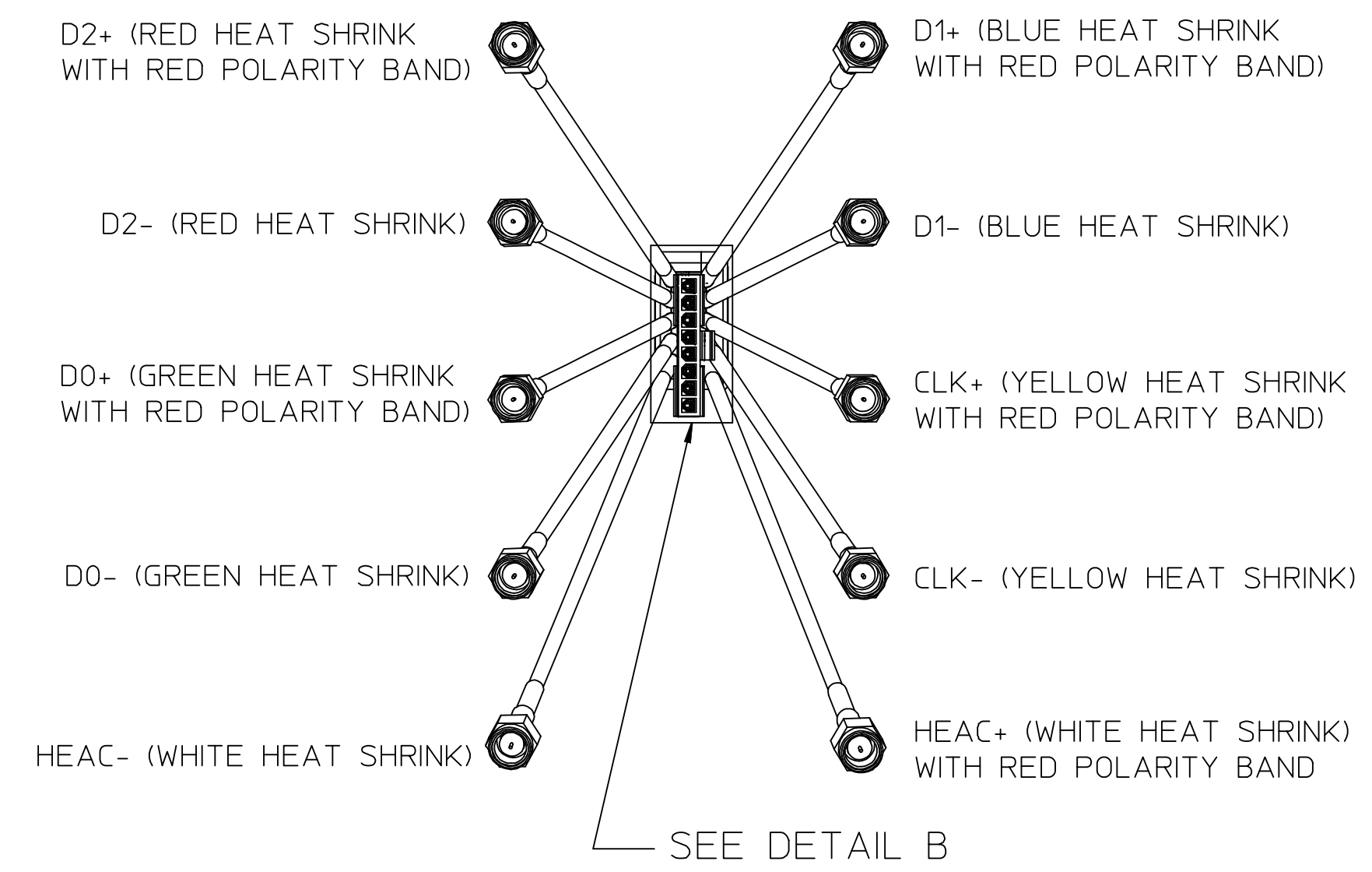
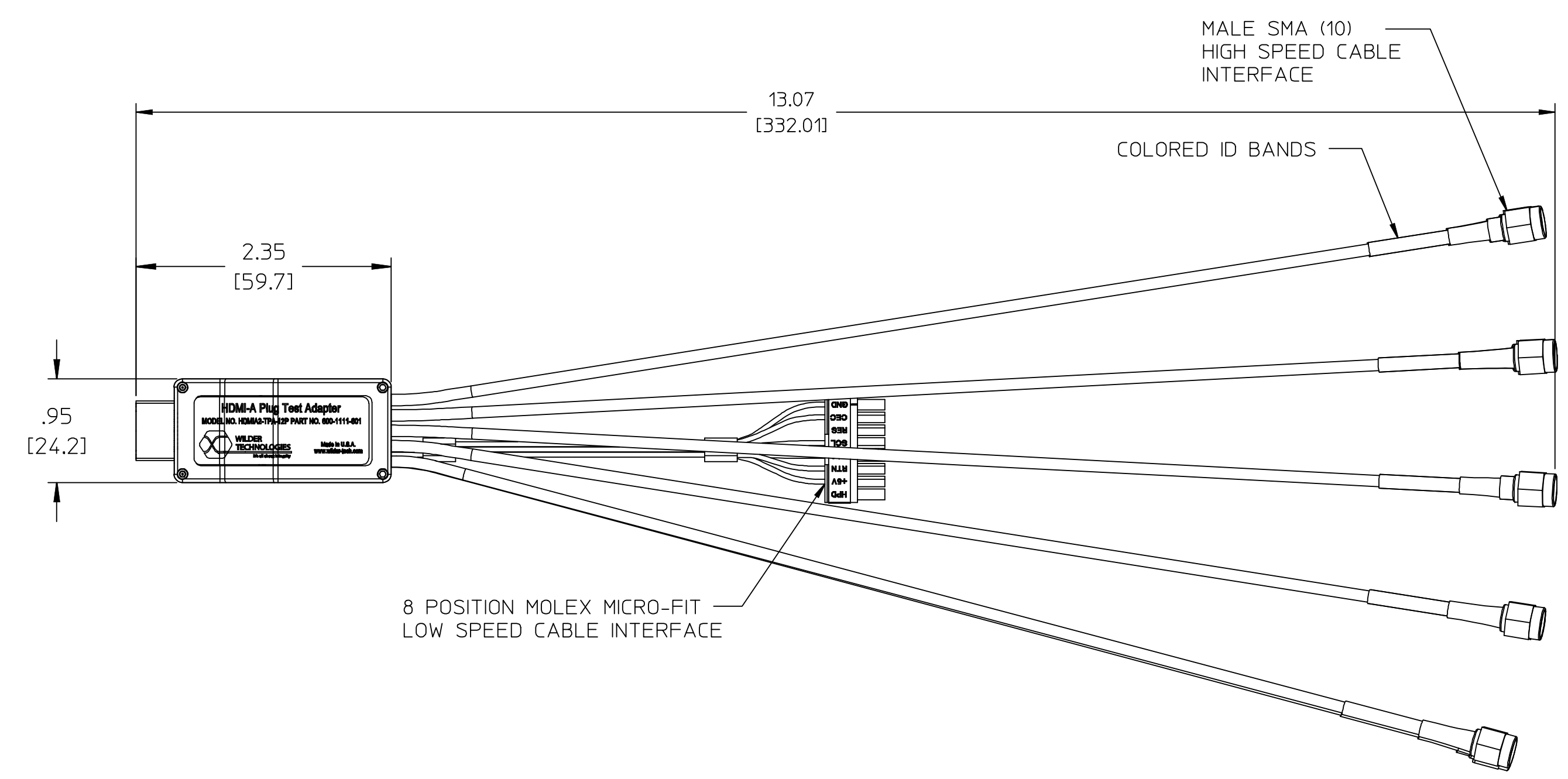
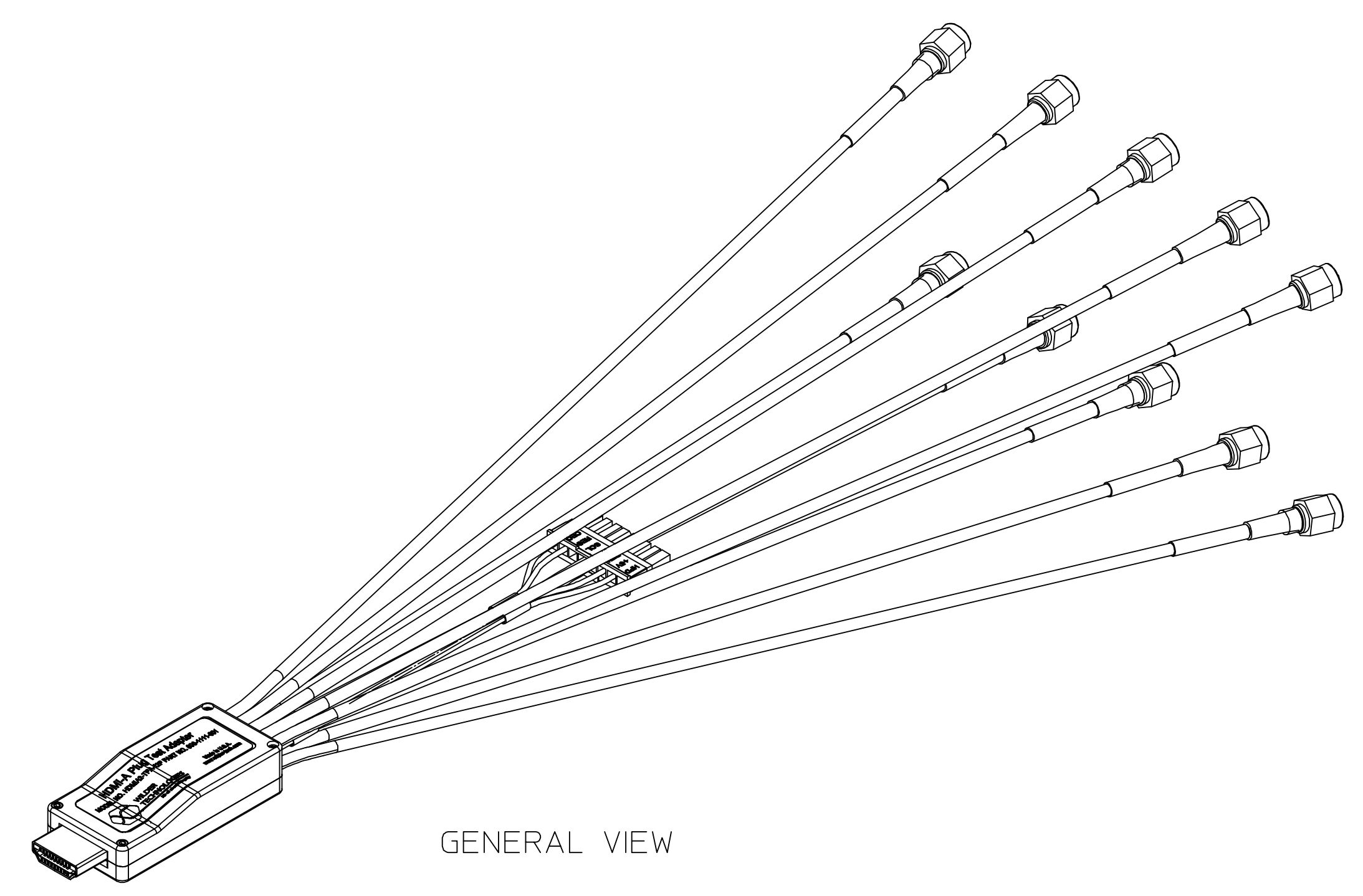

3. THE LOW SPEED INTRFACE CABLE ASSEMBLY HAS A SEPARATE INTERFACE PLUG AND CONTACTS SUPPLIED TO ALLOW USERS TO CONNECT TO THIS ASSEMBLY.
 2. REFER TO THE USERS MANUAL FOR DETAILED MECHANICAL AND ELECTRICAL SPECIFICATIONS.
 1. INTERPRET DIMENSIONS AND TOLERANCES PER ANSI Y14.5.
- NOTE: UNLESS OTHERWISE SPECIFIED

UNLESS OTHERWISE SPECIFIED DIMENSIONS ARE INCHES [METRIC]		4101A Eave 18th St. Vancouver, WA 98661 Tel: 360-859-3041 Fax: 360-859-3105 www.wilder-tech.com	
.XXX + .005 + .027 +		DRAWN BY: W. STANLEY	DATE: 7/29/16
.XX + .01 + .25 +		CHECKED BY:	DATE:
X + .12 + .3 +		APPROVED BY:	DATE:
ANGLE + 1°		DESCRIPTION: FINAL ASSEMBLY, HDMI2, NY PLUG, HEAC, 12 INCH MALE SMA HDMI2-TPA-12P	
FINISH: NA	SIZE PART NUMBER: D 600-1111-601	SCALE: 1:1	REV A
		DO NOT SCALE DRAWING SHEET 1 OF 2	