

THIS DOCUMENT CONTAINS PROPRIETARY INFORMATION AND IS THE PROPERTY OF WILDER TECHNOLOGIES. THIS INFORMATION SHALL NOT BE REPRODUCED, TRANSFERRED TO OTHER DOCUMENTS, DISCLOSED TO OTHERS FOR MANUFACTURING OR ANY OTHER PURPOSE WITHOUT WRITTEN PERMISSION FROM WILDER TECHNOLOGIES.

REVISIONS				
REV	AUTH	DESCRIPTION	APVD DATE	CHK DATE
A	ECNXXXX	INITIAL RELEASE	WS	7/29/16

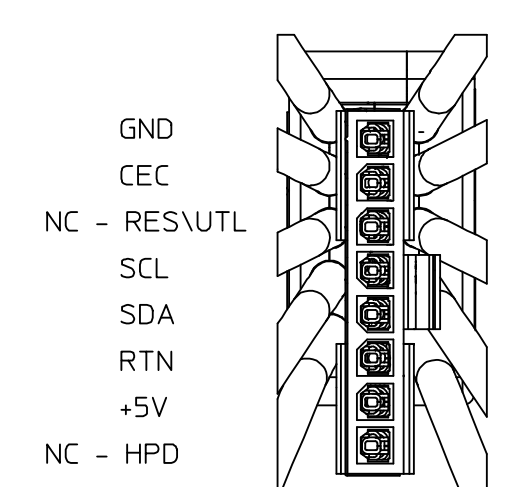
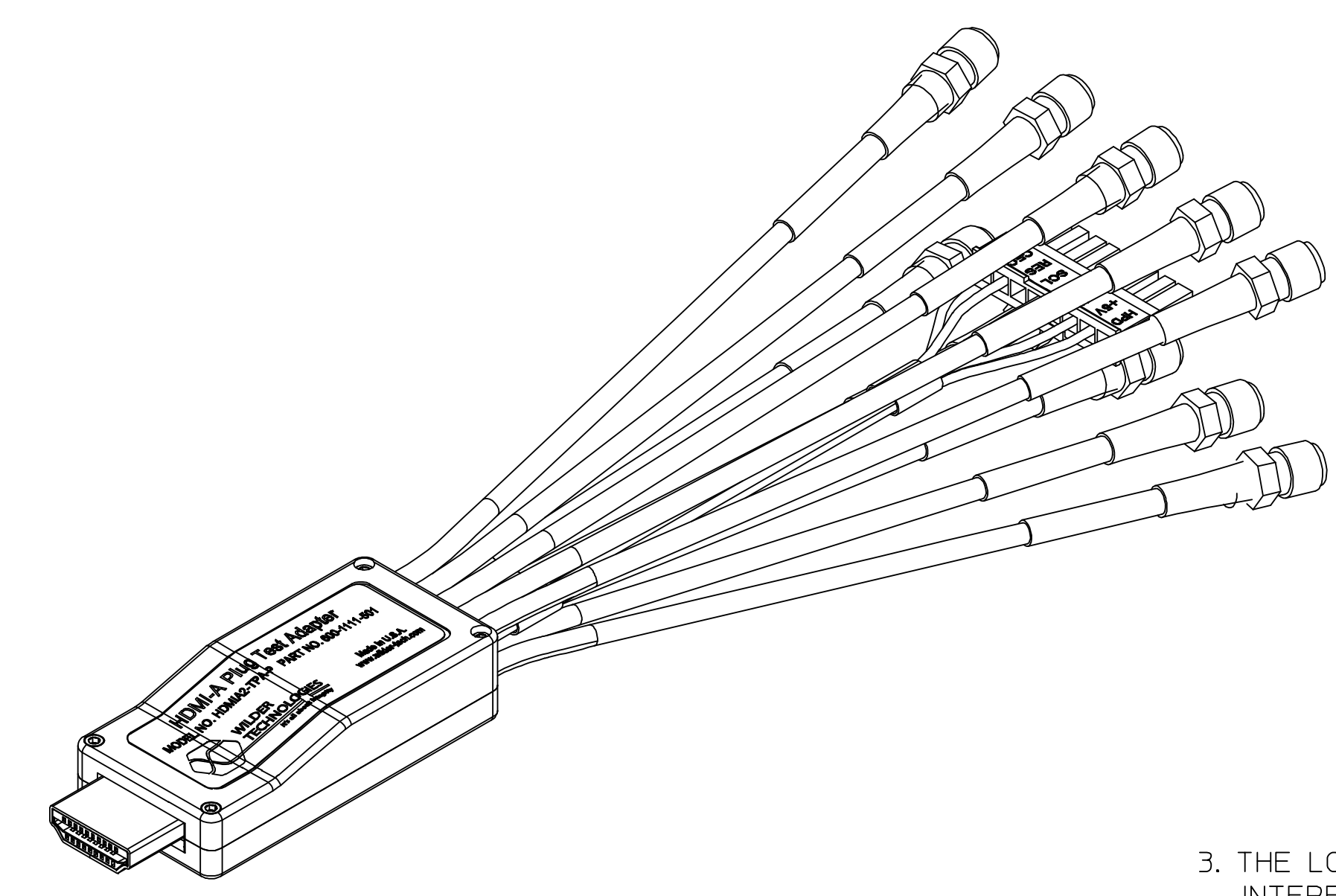
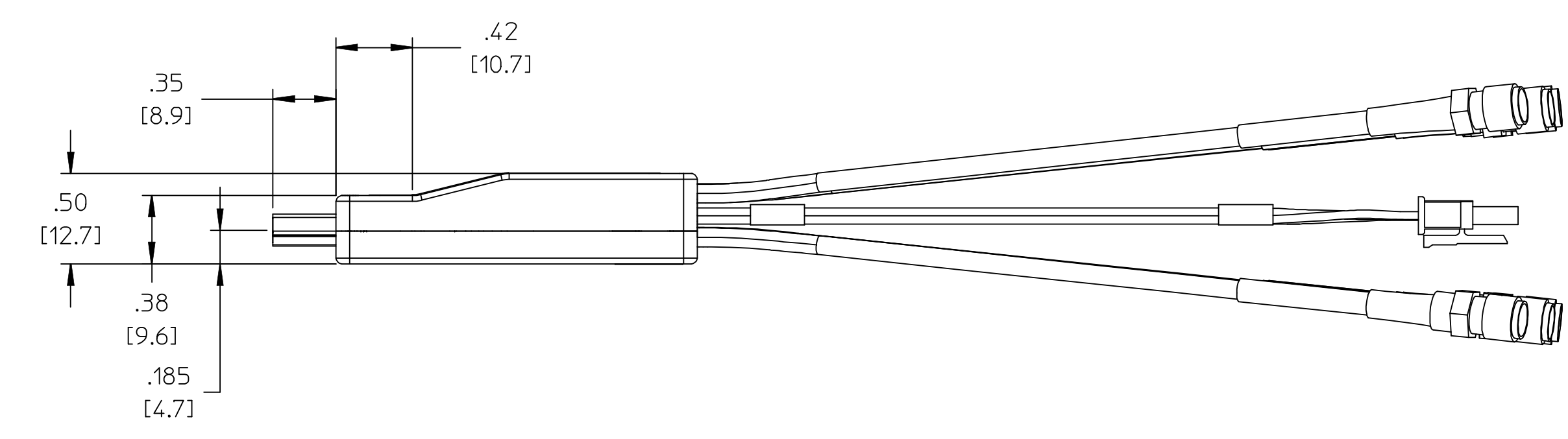
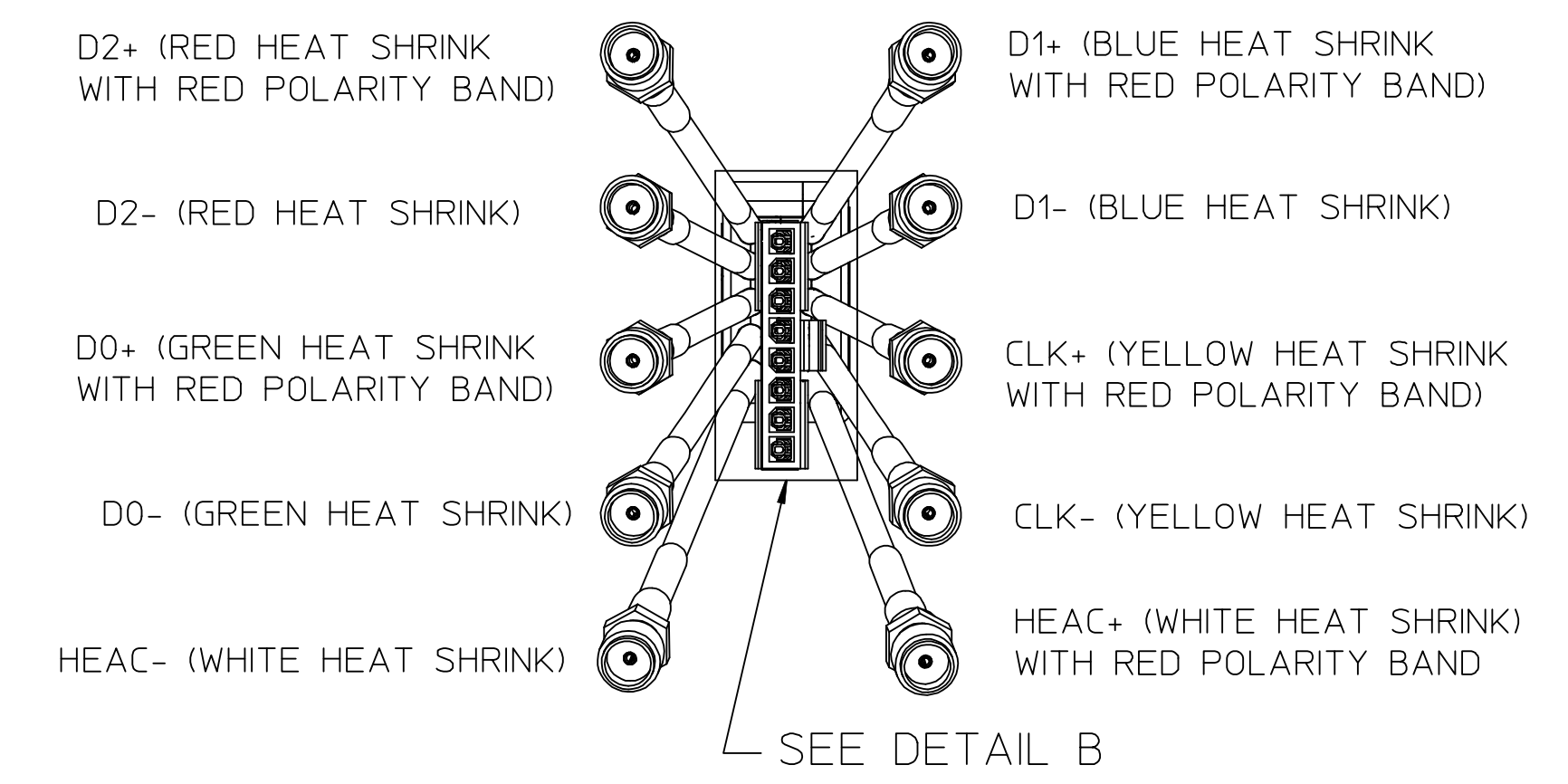
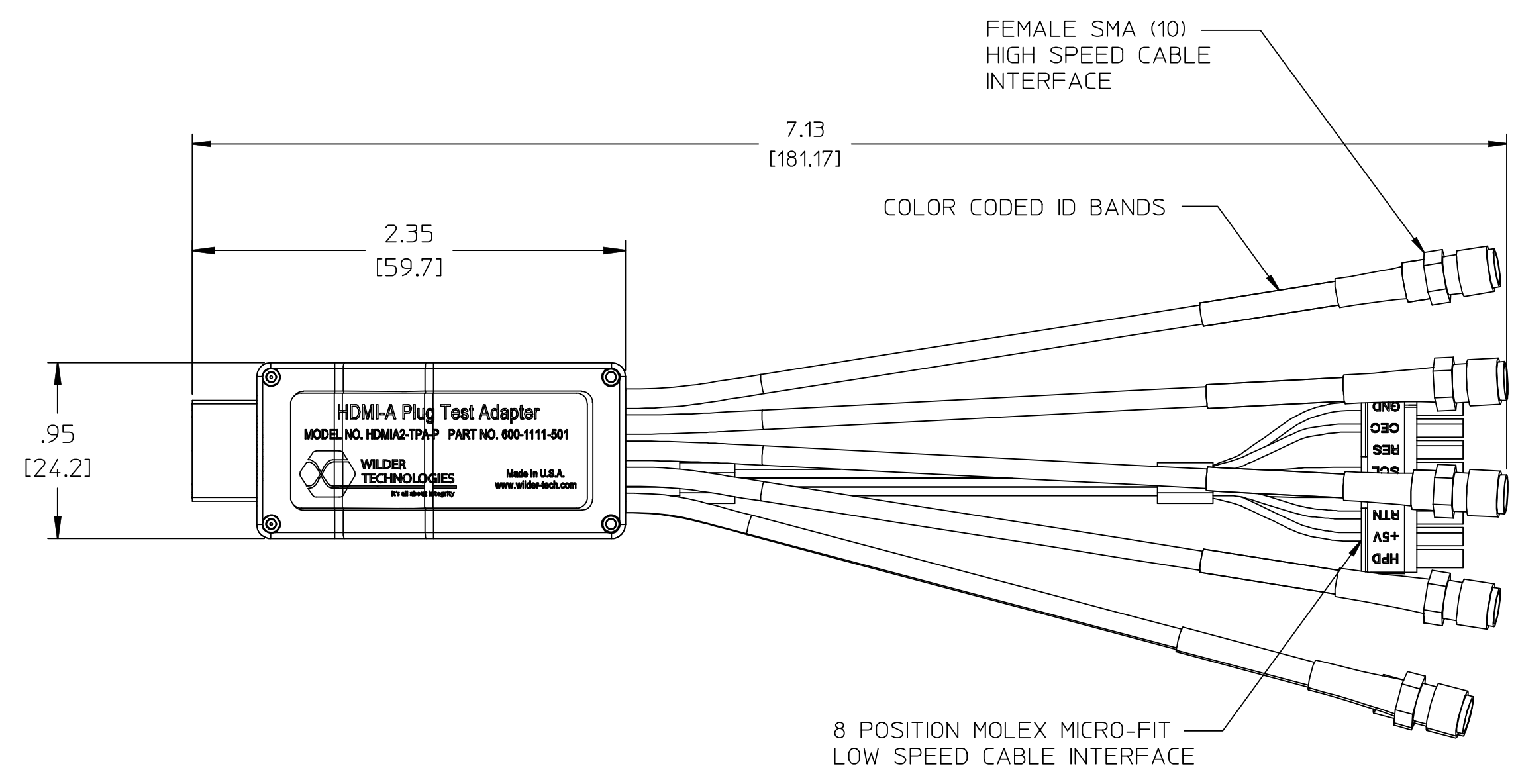

DETAIL B - SCALE 2:1
SCALE 2:1

1. INTERPRET DIMENSIONS AND TOLERANCES PER ANSI Y14.5.
 2. REFER TO THE USERS MANUAL FOR DETAILED MECHANICAL AND ELECTRICAL SPECIFICATIONS.
 3. THE LOW SPEED INTERFACE CABLE ASSEMBLY HAS A SEPARATE INTERFACE PLUG AND CONTACTS SUPPLIED TO ALLOW USERS TO CONNECT TO THIS ASSEMBLY.
- NOTE: UNLESS OTHERWISE SPECIFIED

UNLESS OTHERWISE SPECIFIED DIMENSIONS ARE INCHES (METRIC)		WILDER TECHNOLOGIES		4101A E. 18th St. Vancouver, WA 98661	
.XXX + .005 + .027 +		DRAWN BY: W.STANLEY		DATE: 7/29/16	
.XX + .01 + .25 +		CHECKED BY:		DATE:	
X + .12 + .3 +		APPROVED BY:		DATE:	
ANGLE + 1°		DESCRIPTION: FINAL ASSEMBLY, HDMIA2, NY PLUG HDMIA2-TPA-P			
MATERIAL: SEE SEPARATE BILL OF MATERIAL		FINISH: NA		SIZE PART NUMBER: D 600-1111-501	
		SCALE: 15:1		DO NOT SCALE DRAWING SHEET 1 OF 2	
				REV A	