

THIS DOCUMENT CONTAINS PROPRIETARY INFORMATION AND IS THE PROPERTY OF WILDER TECHNOLOGIES. THIS INFORMATION SHALL NOT BE REPRODUCED, TRANSFERRED TO OTHER DOCUMENTS, DISCLOSED TO OTHERS FOR MANUFACTURING OR ANY OTHER PURPOSE WITHOUT WRITTEN PERMISSION FROM WILDER TECHNOLOGIES.

REVISIONS				
REV	AUTH	DESCRIPTION	APVD DATE	CHK DATE
A	ECNXXXX	PRELIMINARY RELEASE		A

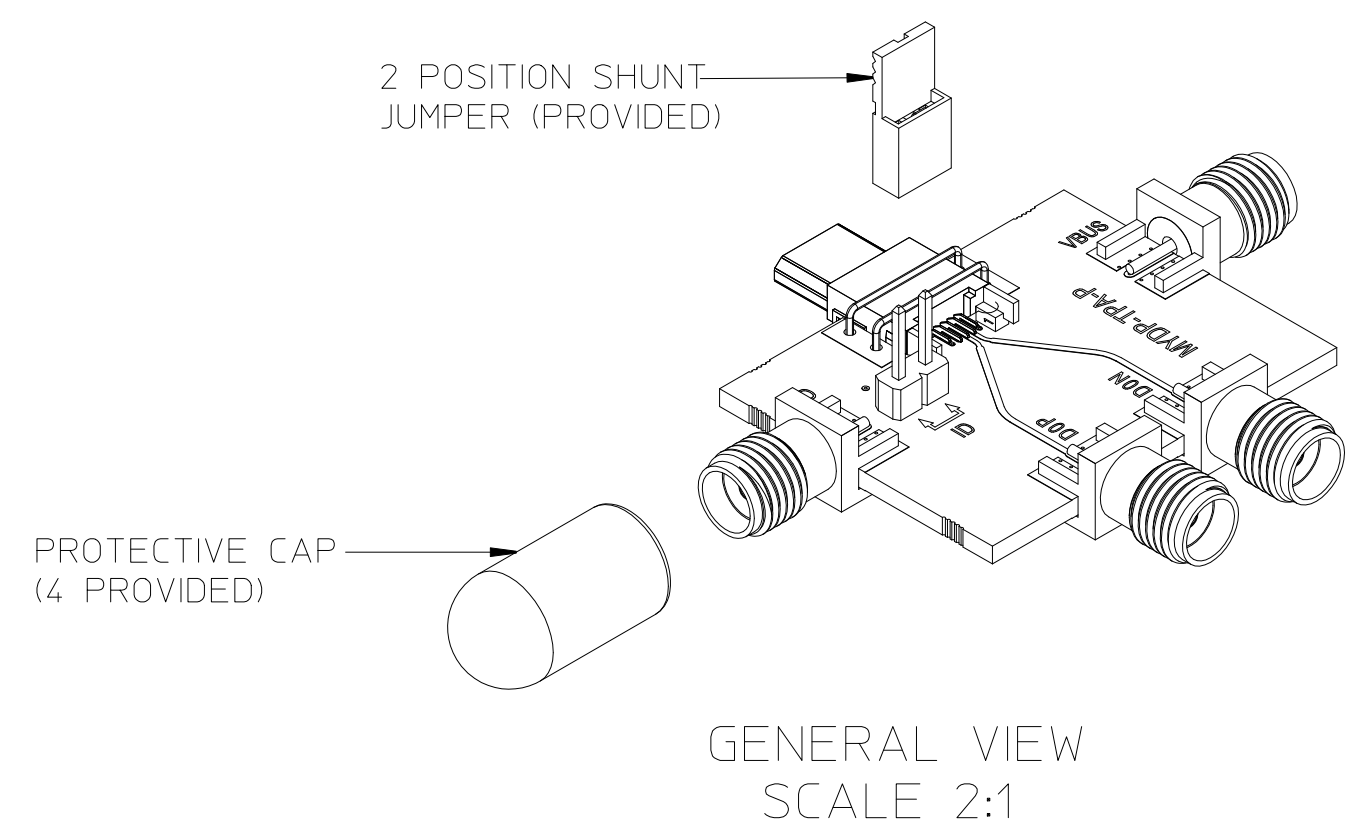
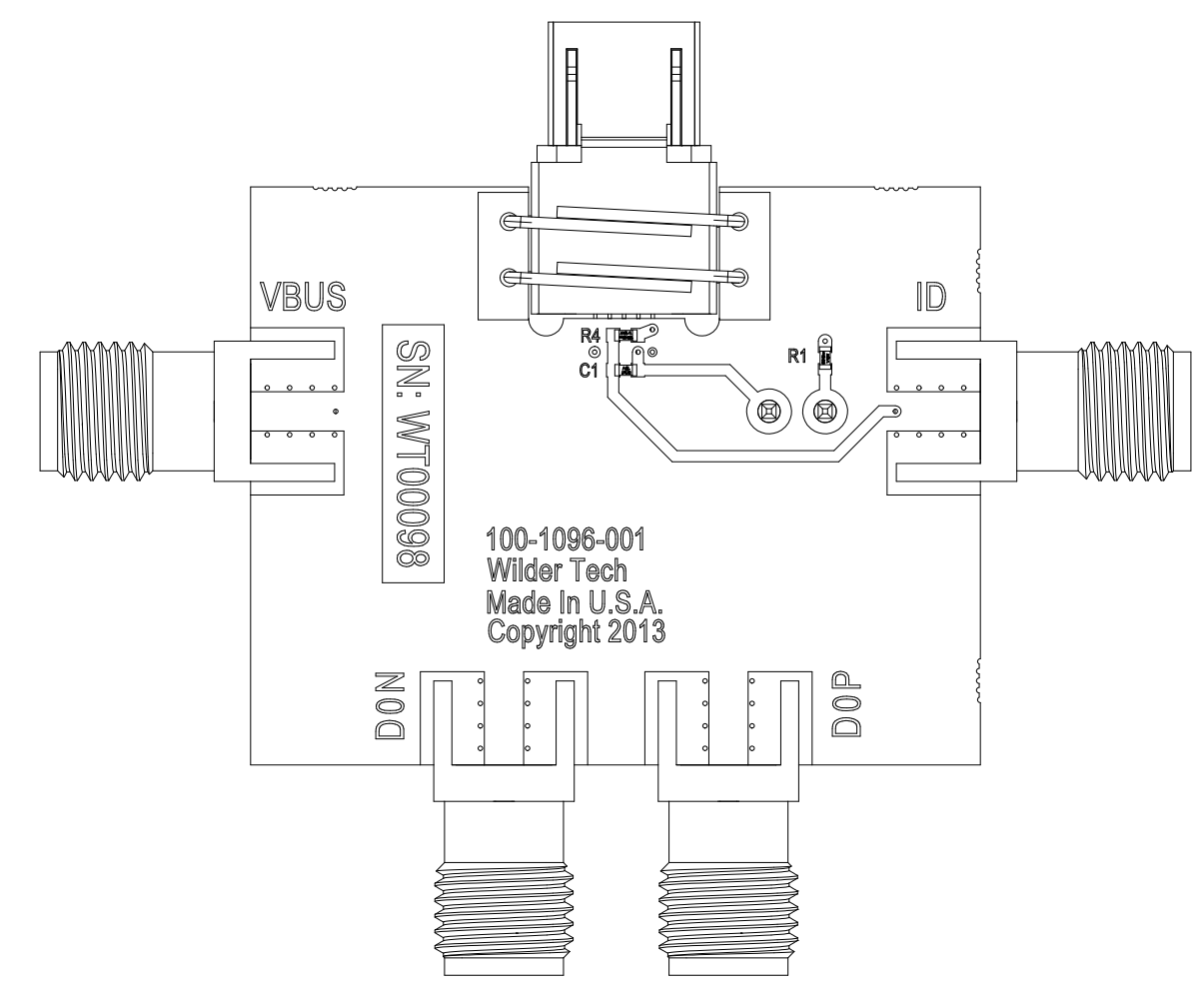
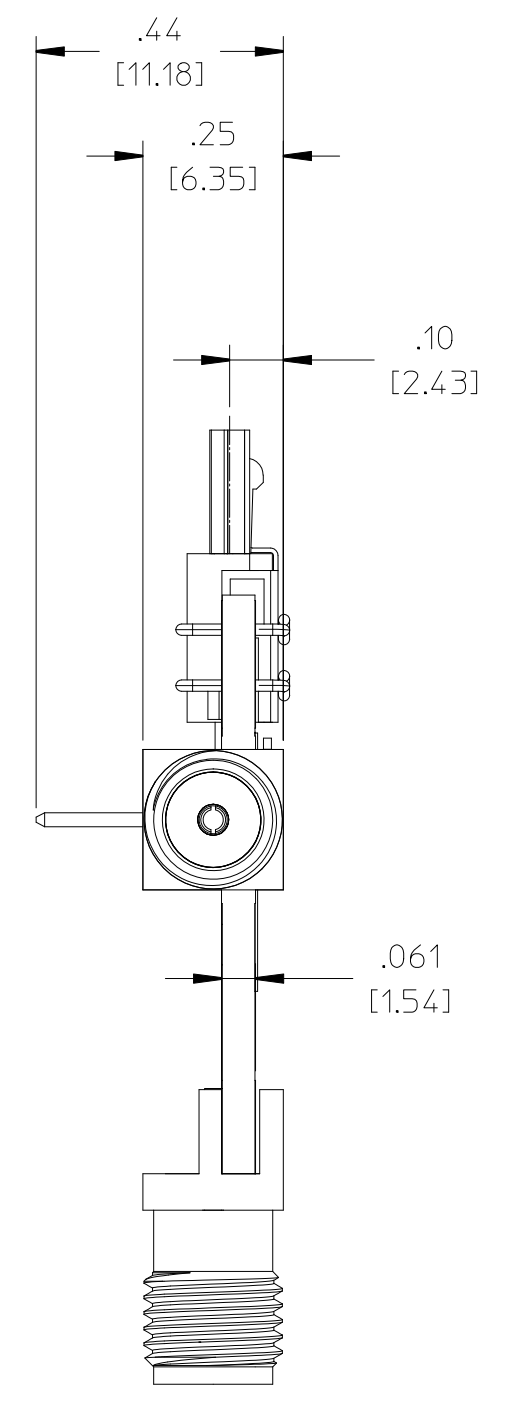
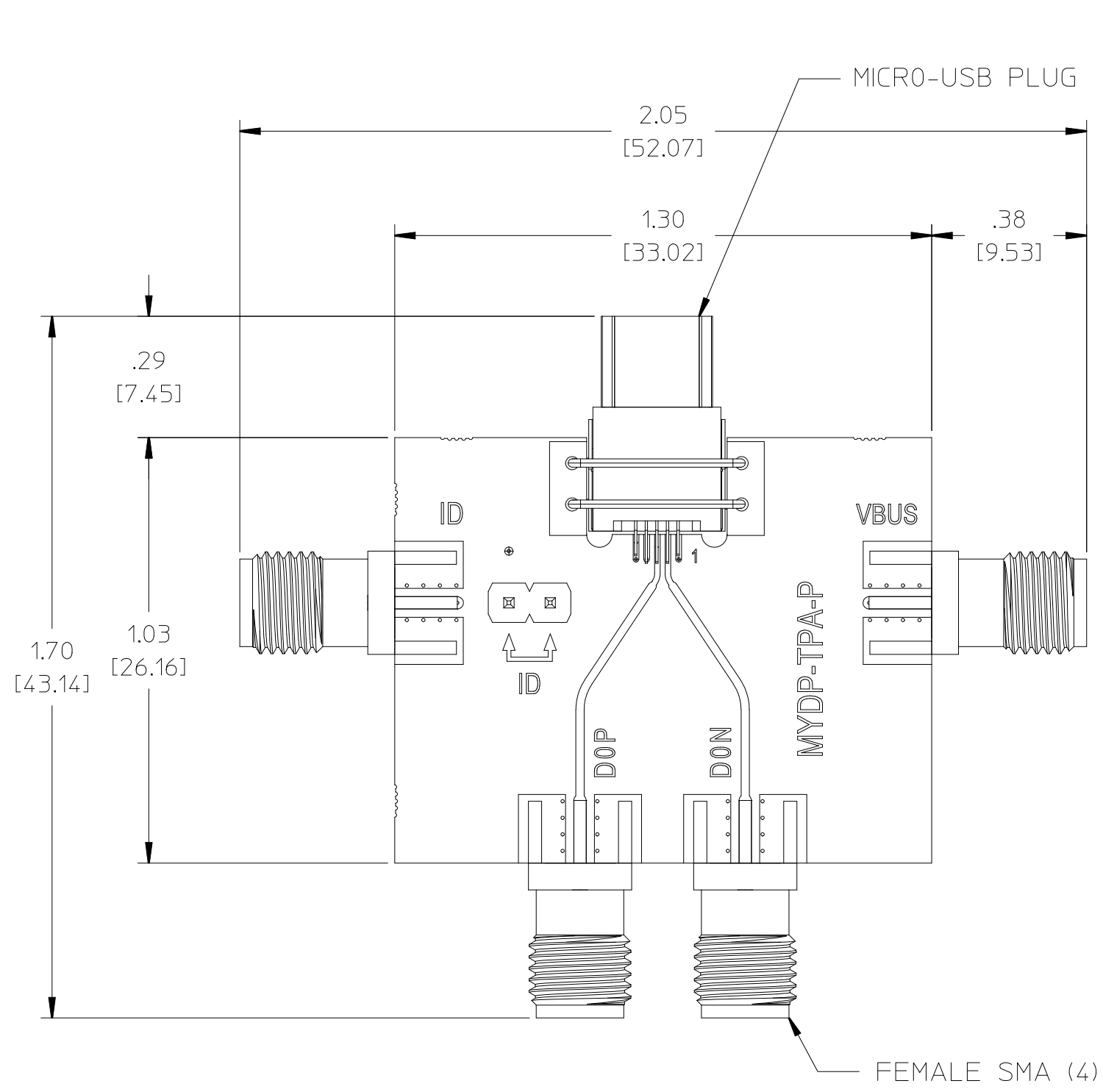

GENERAL VIEW
SCALE 2:1

- REFER TO USERS MANUAL FOR DETAILED MECHANICAL AND ELECTRICAL SPECIFICATIONS. WILDER TECHNOLOGIES PART NUMBER 910-0031-000.
 - LEAD-FREE PROCESSES USED FOR ASSEMBLY OF THIS PCA AND COMPLIES WITH DIRECTIVE 2002/95/EC (RoHS DIRECTIVE) RESTRICTIVE USE OF HAZARDOUS MATERIALS.
 - INTERPRET DIMENSIONS AND TOLERANCES PER ANSI Y14.5.
- NOTE: UNLESS OTHERWISE SPECIFIED

UNLESS OTHERWISE SPECIFIED DIMENSIONS ARE INCHES (METRIC)		6101A East 18th St. Vancouver, WA 98661 Tel: 360-859-3041 Fax: 360-859-3105 www.wilder-tech.com	
.XXX ± .005 ± .127 ±	.XX ± .01 ± .25 ±	DRAWN BY: W. STANLEY DATE: 4-12-13	
.X ± .12 ± .3 ±	ANGLE ± 1° ± 1°	CHECKED BY: DATE:	
MATERIAL:		APPROVED BY: DATE:	
FINISH:		DESCRIPTION:	
		ASSEMBLY, ECB, TEST ADAPTER, MYDP-TPA-P	
SIZE: C	PART NUMBER: 110-1096-001	REV: A	
SCALE: 3:1	DO NOT SCALE DRAWING	SHEET 2 OF 2	