

THIS DOCUMENT CONTAINS PROPRIETARY INFORMATION AND IS THE PROPERTY OF WILDER TECHNOLOGIES. THIS INFORMATION SHALL NOT BE REPRODUCED, TRANSFERRED TO OTHER DOCUMENTS, DISCLOSED TO OTHERS FOR MANUFACTURING OR ANY OTHER PURPOSE WITHOUT WRITTEN PERMISSION FROM WILDER TECHNOLOGIES.

REVISIONS				
REV	AUTH	DESCRIPTION	APVD DATE	CHK DATE
A	ECNXXXX	INITIAL RELEASE		1/21/2011

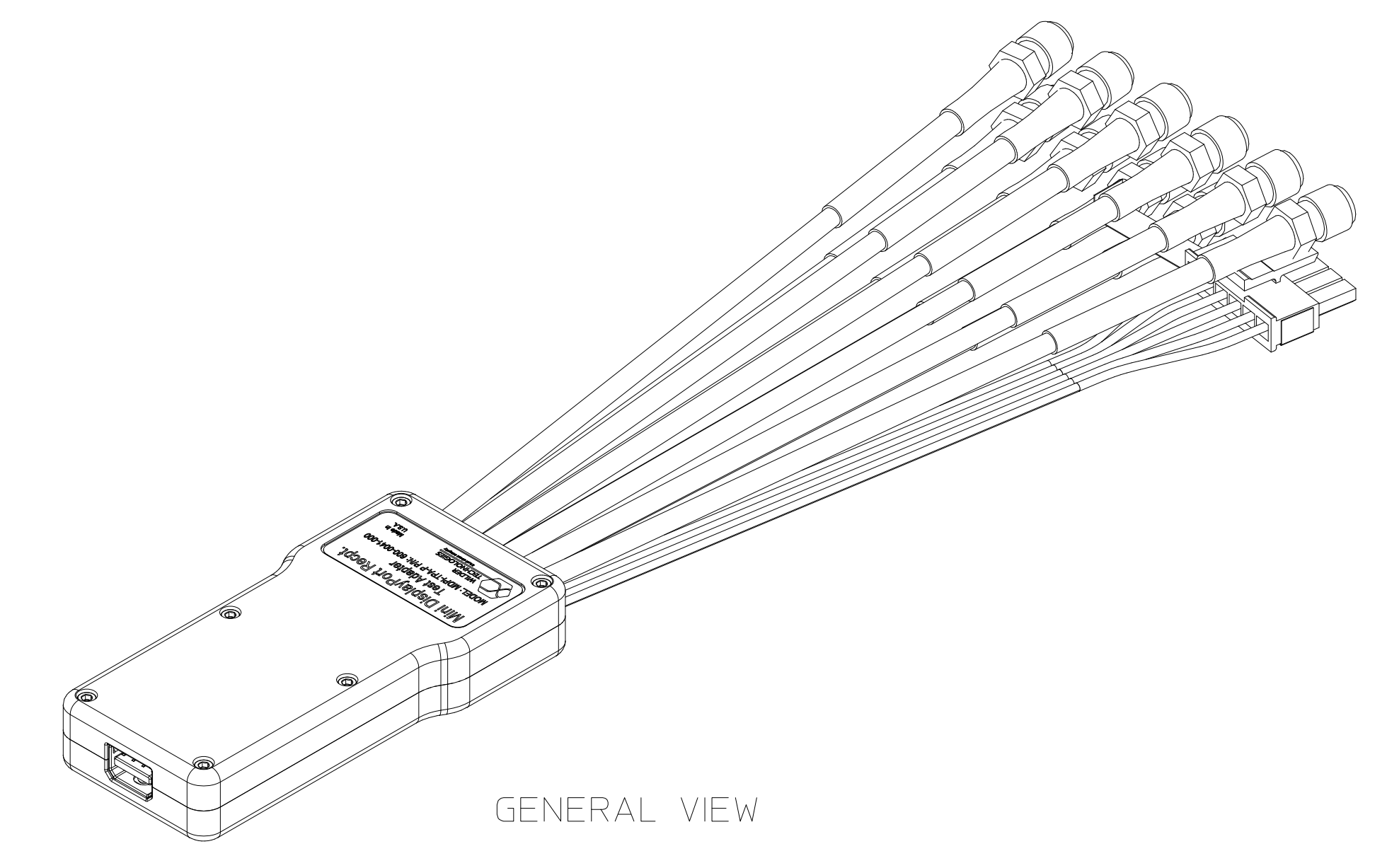
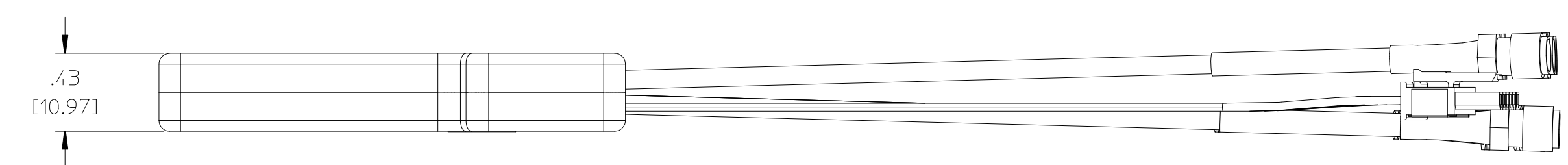
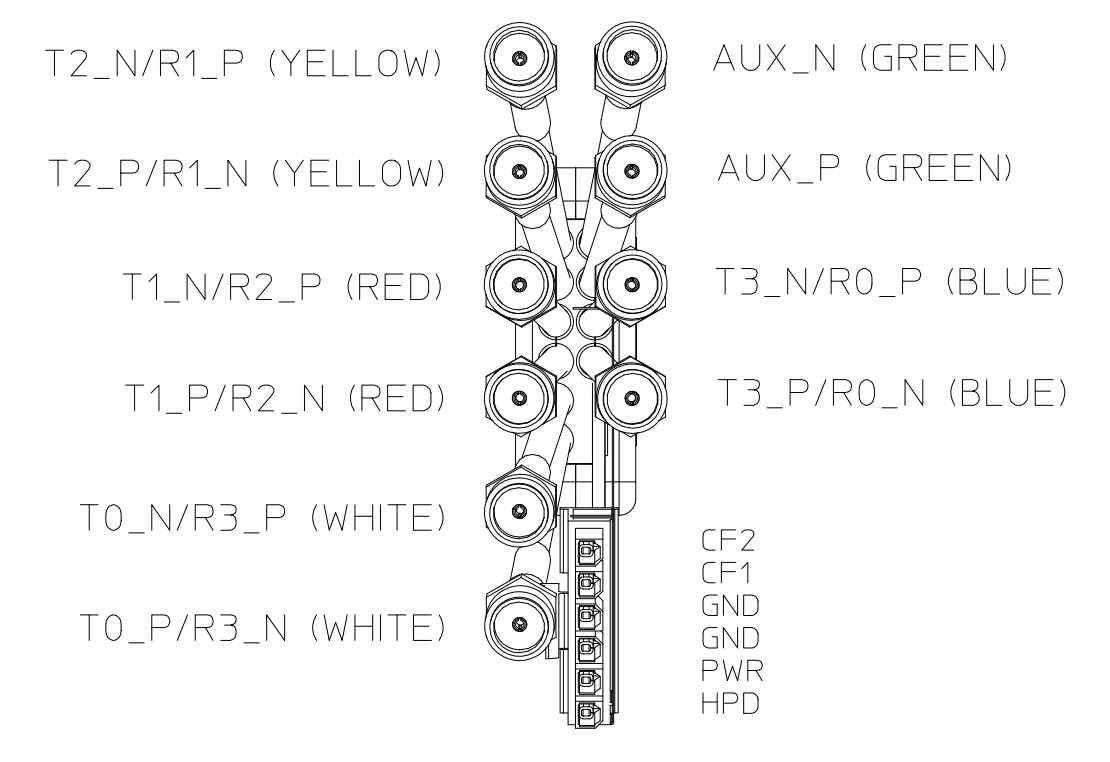
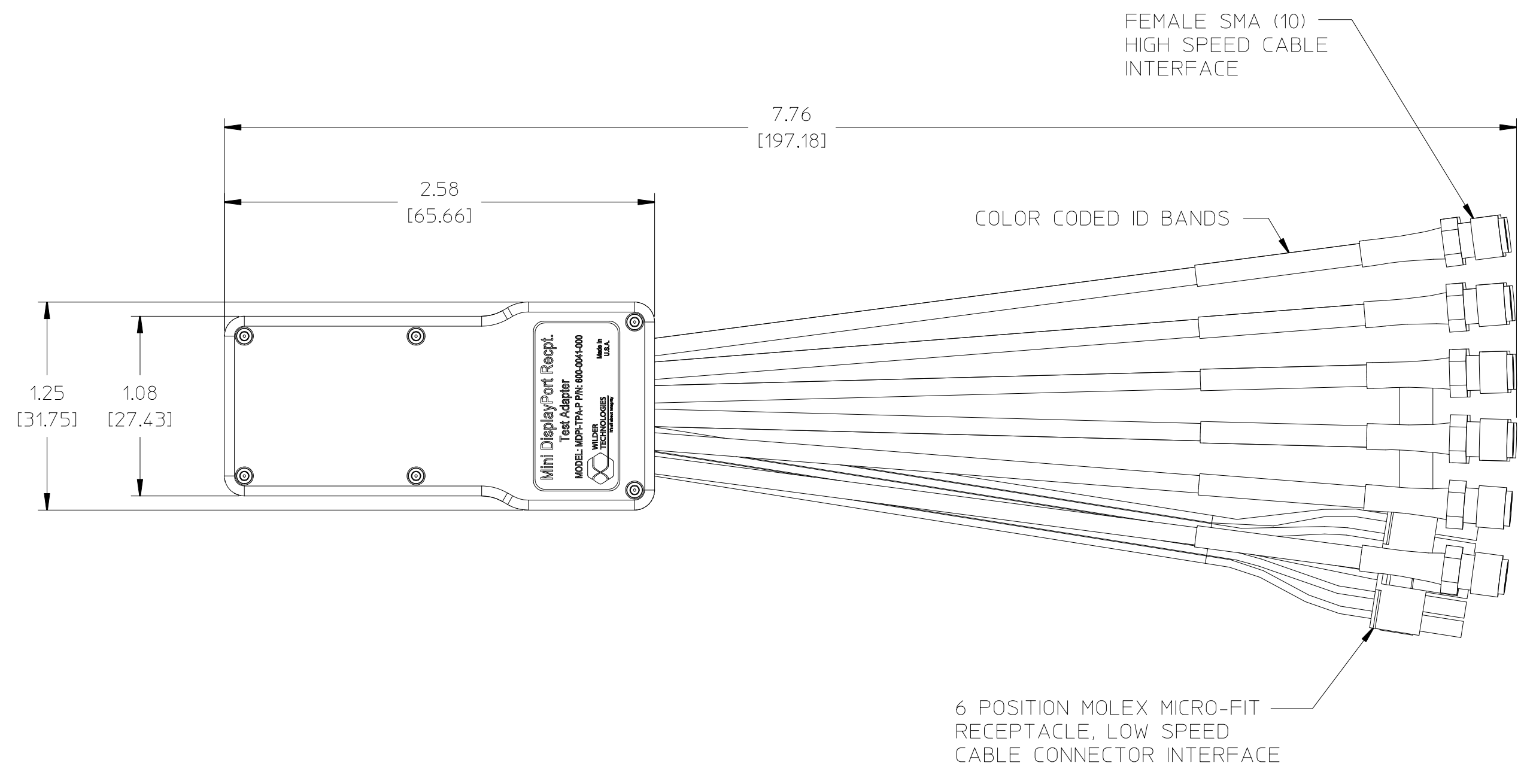

- NOTE: UNLESS OTHERWISE SPECIFIED
1. INTERPRET DIMENSIONS AND TOLERANCES PER ANSI Y14.5.
  2. REFER TO THE USERS MANUAL FOR DETAILED MECHANICAL AND ELECTRICAL SPECIFICATIONS.
  3. THE LOW-SPEED CONNECTOR INTERFACE RECEPTACLE CONNECTOR PLUG AND CONTACT PINS ARE PROVIDED WITH THIS PRODUCT FOR USERS.

<small>UNLESS OTHERWISE SPECIFIED DIMENSIONS ARE INCHES (METRIC)</small> .XXX ± .005 ± .127 ± .XX ± .01 ± .25 ± .X ± .02 ± .3 ± ANGLE ± 1° ± 1°		6101A East 18th St Vancouver, WA 98661 Tel: 360-859-3041 Fax: 360-859-3105 www.wilder-tech.com
	DRAWN BY: W. STANLEY CHECKED BY: APPROVED BY:	DATE: 1/21/2011 DATE: DATE:
FINISH:	SIZE PART NUMBER: <b>D</b> 600-1041-000	REV <b>A</b>
SCALE: 1:1	DO NOT SCALE DRAWING	SHEET 3 OF 3