

THIS DOCUMENT CONTAINS PROPRIETARY INFORMATION AND IS THE PROPERTY OF WILDER TECHNOLOGIES. THIS INFORMATION SHALL NOT BE REPRODUCED, TRANSFERRED TO OTHER DOCUMENTS, DISCLOSED TO OTHERS FOR MANUFACTURING OR ANY OTHER PURPOSE WITHOUT WRITTEN PERMISSION FROM WILDER TECHNOLOGIES.

REVISIONS				
REV	AUTH	DESCRIPTION	APVD DATE	CHK DATE
A	ECNXXXX	INITIAL RELEASE		1-20-22
A	ECNXXXX	ADD FAN NOTATION AS AN ACCESSORY, UPDATE NOTE 2		4-4-23

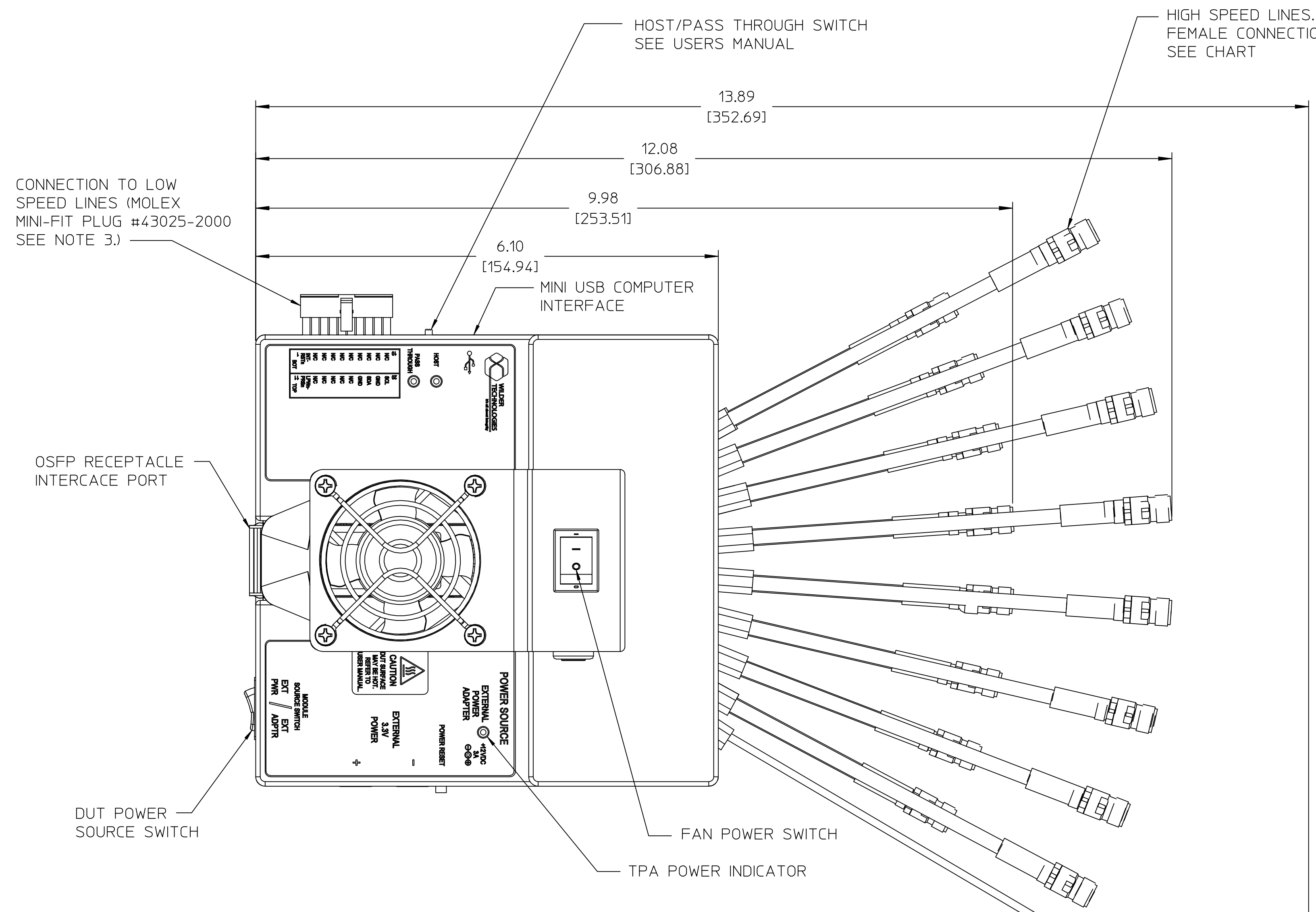

- | | |
|--------------------------------------|-------------------------------------|
| TX1+ YELLOW WITH RED AND WHITE BANDS | TX2+ BLUE WITH WHITE AND RED BANDS |
| TX1- YELLOW WITH WHITE BAND | TX2- BLUE WITH WHITE BAND |
| TX3+ GREEN WITH RED AND WHITE BANDS | TX4+ RED WITH WHITE AND RED BANDS |
| TX3- GREEN WITH WHITE BAND | TX4- RED WITH WHITE BAND |
| TX5+ ORANGE WITH RED AND WHITE BANDS | TX6+ BROWN WITH WHITE AND RED BANDS |
| TX5- ORANGE WITH WHITE BAND | TX6- BROWN WITH WHITE BAND |
| TX7+ VIOLET WITH RED AND WHITE BANDS | TX8+ WHITE WITH WHITE AND RED BANDS |
| TX7- VIOLET WITH WHITE BAND | TX8- WHITE WITH WHITE BAND |
| RX8- WHITE | RX7- VIOLET |
| RX8+ WHITE WITH RED BAND | RX7+ VIOLET WITH RED BAND |
| RX6- BROWN | RX5- ORANGE |
| RX6+ BROWN WITH RED BAND | RX5+ ORANGE WITH RED BAND |
| RX4- RED | RX3- GREEN |
| RX4+ RED WITH RED BAND | RX3+ GREEN WITH RED BAND |
| RX2- BLUE | RX1- YELLOW |
| RX2+ BLUE WITH RED BAND | RX1+ YELLOW WITH RED BAND |
- PORT CODING
UPPER 16 LINES
- PORT CODING
LOWER 16 LINES

NOTE:
RED BAND = POSITIVE
WHITE BAND = TRANSMIT

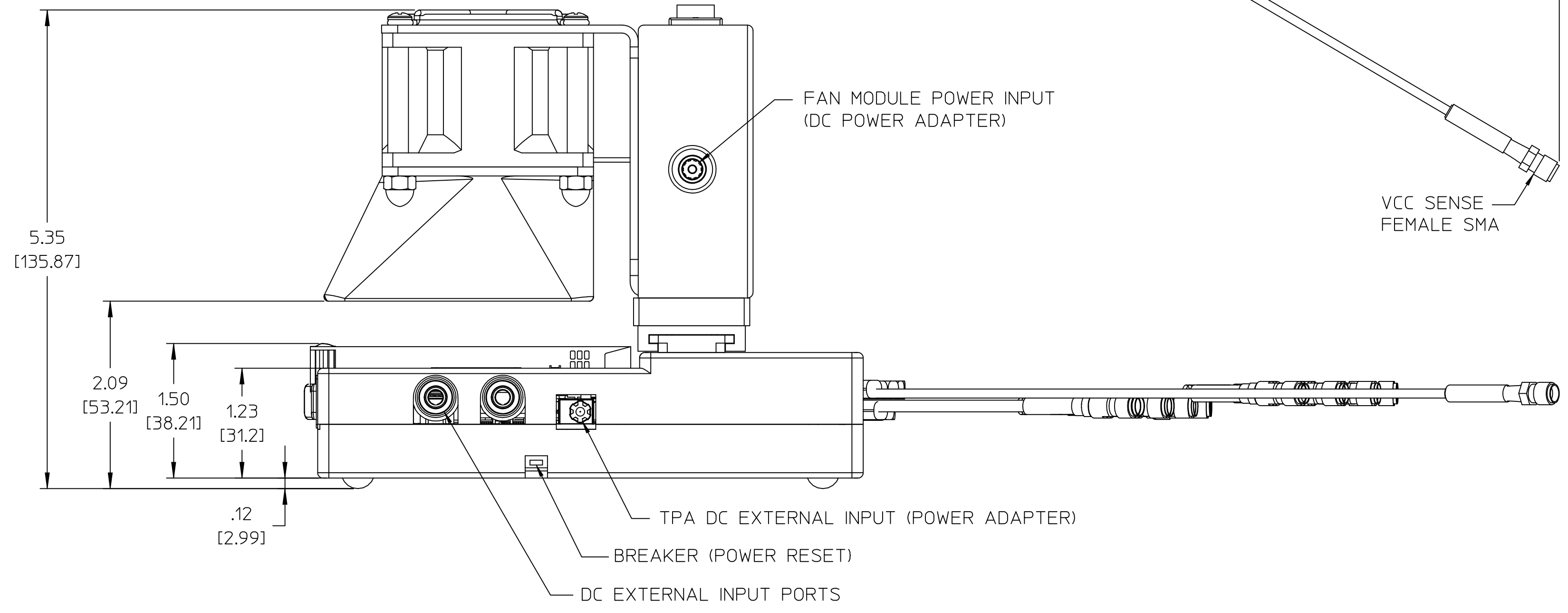

NOTE:
THE AIR MOVER ASSEMBLY IS SUPPLIED AS AN ACCESSORY TO THIS UNIT AND IS REPRESENTED HERE FOR DIMENSIONAL REFERENCENCES ONLY

- NOTE: UNLESS OTHERWISE SPECIFIED
1. INTERPRET DIMENSIONS AND TOLERANCES PER ANSI Y14.5.
 2. FOR DETAILED MECHANICAL AND ELECTRICAL SPECIFICATIONS REFER TO USERS MANUAL 910-0061-000.
 3. THIS TEST ADAPTER IS SUPPLIED WITH A SEPARATE 20 POSITION RECEPTACLE AND RECEPTACLE PINS TO ALLOW USERS TO CONNECT TO THIS ASSEMBLY.
MOLEX HOUSING NUMBER - 43025-2000
MOLEX CONTACT PINS - 43030-0011
 4. LEAD-FREE PROCESSES REQUIRED. MUST COMPLY WITH EC DIRECTIVE 2011/65/EU AND AMENDMENT DIRECTIVE (EU) 2015/863(RoHS2 DIRECTIVE) RESTRICTIVE USE OF HAZARDOUS SUBSTANCES.

600-1216-200	1.85mm FEMALE
600-1216-100	2.4mm FEMALE
600-1216-000	2.92mm FEMALE
MODEL NUMBER	HIGH SPEED CABLE TERMINATION STYLE

THIS DRAWING IS FOR REFERENCE ONLY AND APPLIES TO 3 MODLES OF OSFP

UNLESS OTHERWISE SPECIFIED DIMENSIONS ARE INCHES (METRIC)		6101 A East 18th St. Vancouver, WA 98661 Tel: 360-859-3041 Fax: 360-859-3105 www.wilder-tech.com	
DATE: 9-1-21	CHECKED BY: W. STANLEY	DATE:	DATE:
DATE:	DATE:	DATE:	DATE:
MATERIAL:		DESCRIPTION:	
OSFP MCB, 400/800G, w/AIR MOVER ASSEMBLY, CUSTOMER REFERENCE DRAWING		OSFP MCB, 400/800G, w/AIR MOVER ASSEMBLY, CUSTOMER REFERENCE DRAWING	
SIZE: D	PART NUMBER: 600-1216-000_WF	REV: A	REV: A
SCALE: 1:1	DO NOT SCALE DRAWING	SHEET 1 OF 2	

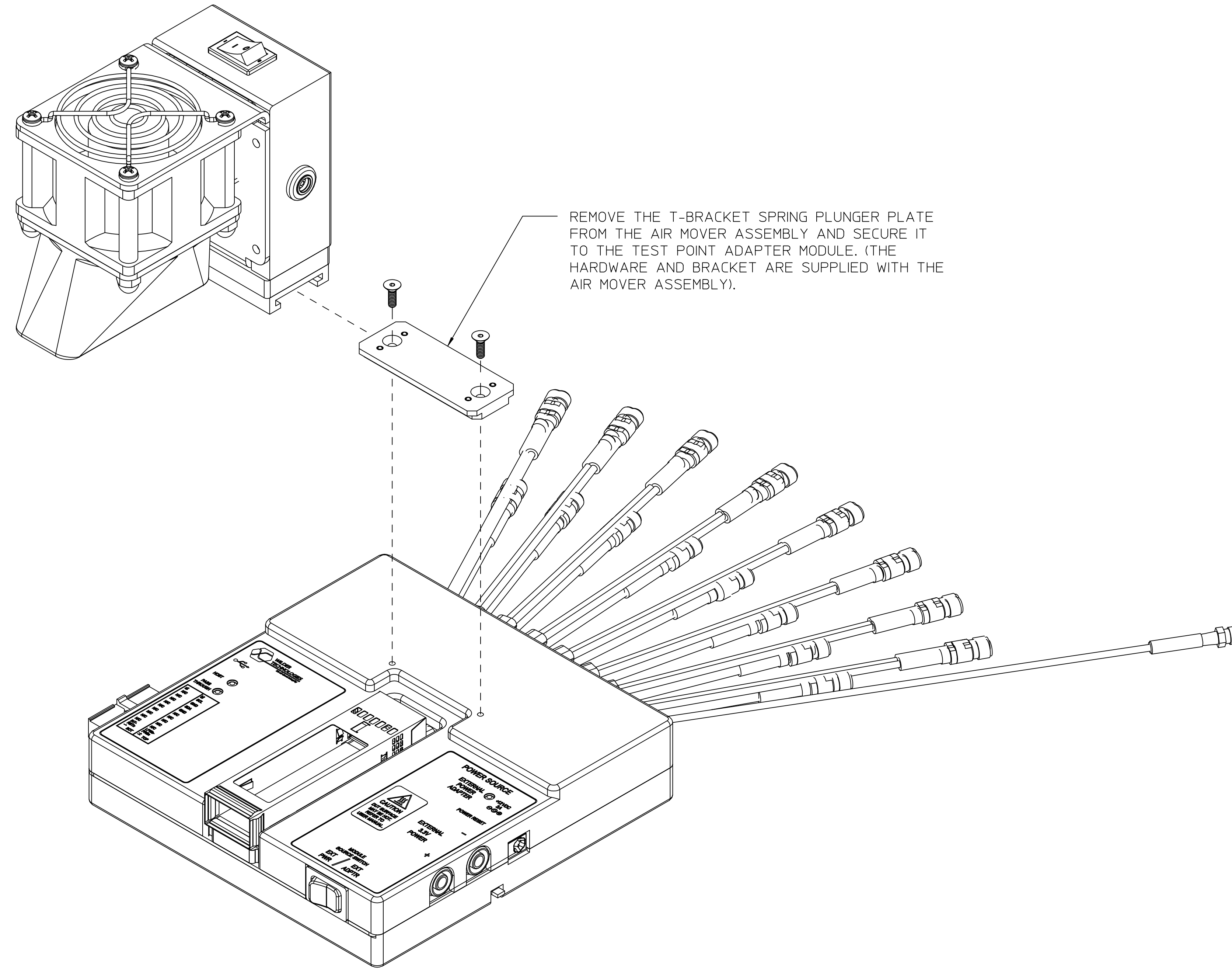

REMOVE THE T-BRACKET SPRING PLUNGER PLATE FROM THE AIR MOVER ASSEMBLY AND SECURE IT TO THE TEST POINT ADAPTER MODULE. (THE HARDWARE AND BRACKET ARE SUPPLIED WITH THE AIR MOVER ASSEMBLY).

AIR MOVER INSTALLATION INSTRUCTIONS

NOTE:
THE AIR MOVER ASSEMBLY IS SUPPLIED AS AN ACCESSORY TO THIS UNIT AND IS REPRESENTED HERE FOR DIMENSIONAL REFERNECES ONLY

NOTE: UNLESS OTHERWISE SPECIFIED

1. ITEMS SUPPLIED WITH THE AIR MOVER ASSEMBLY
 - A. AC POWER CORD, (NEMA 5-15P to Intrl Fem C13 Straight, 6.66Ft, North America)
 - B. AC-DC POWER ADAPTER (18W, 12Vdc, 1.5A, C14 Input, 2.1 x 5.5 x 11 Output Connector)
 - C. T-BRACKET SPRING PLUNGER PLATE w/HARDWARE