

THIS DOCUMENT CONTAINS PROPRIETARY INFORMATION AND IS THE PROPERTY OF WILDER TECHNOLOGIES. THIS INFORMATION SHALL NOT BE REPRODUCED, TRANSFERRED TO OTHER DOCUMENTS, DISCLOSED TO OTHERS FOR MANUFACTURING OR ANY OTHER PURPOSE WITHOUT WRITTEN PERMISSION FROM WILDER TECHNOLOGIES.

REVISIONS				
REV	AUTH	DESCRIPTION	APVD DATE	CHK DATE
A	ECNXXXX	PRELIMINARY RELEASE		3/23/2017

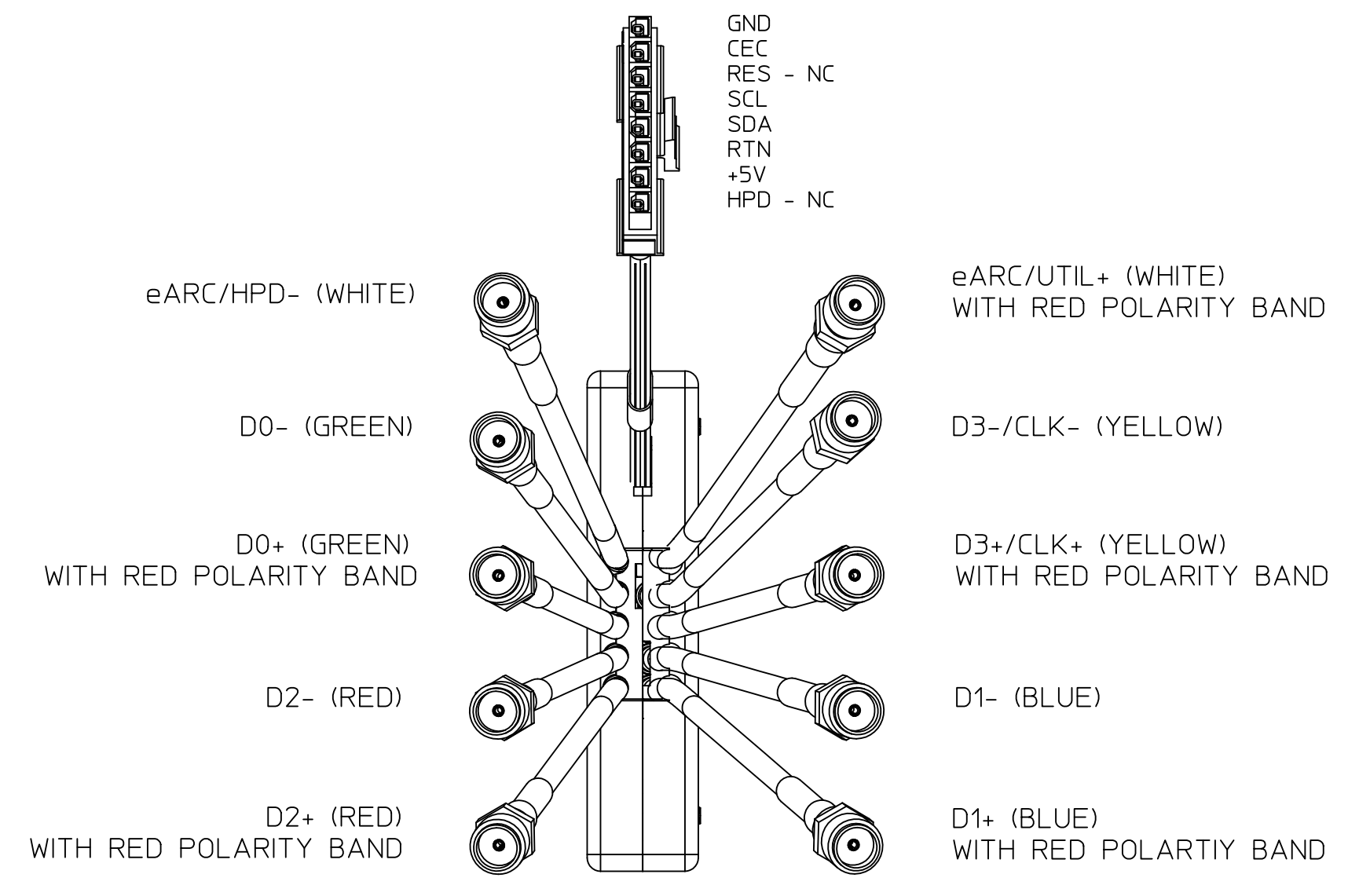
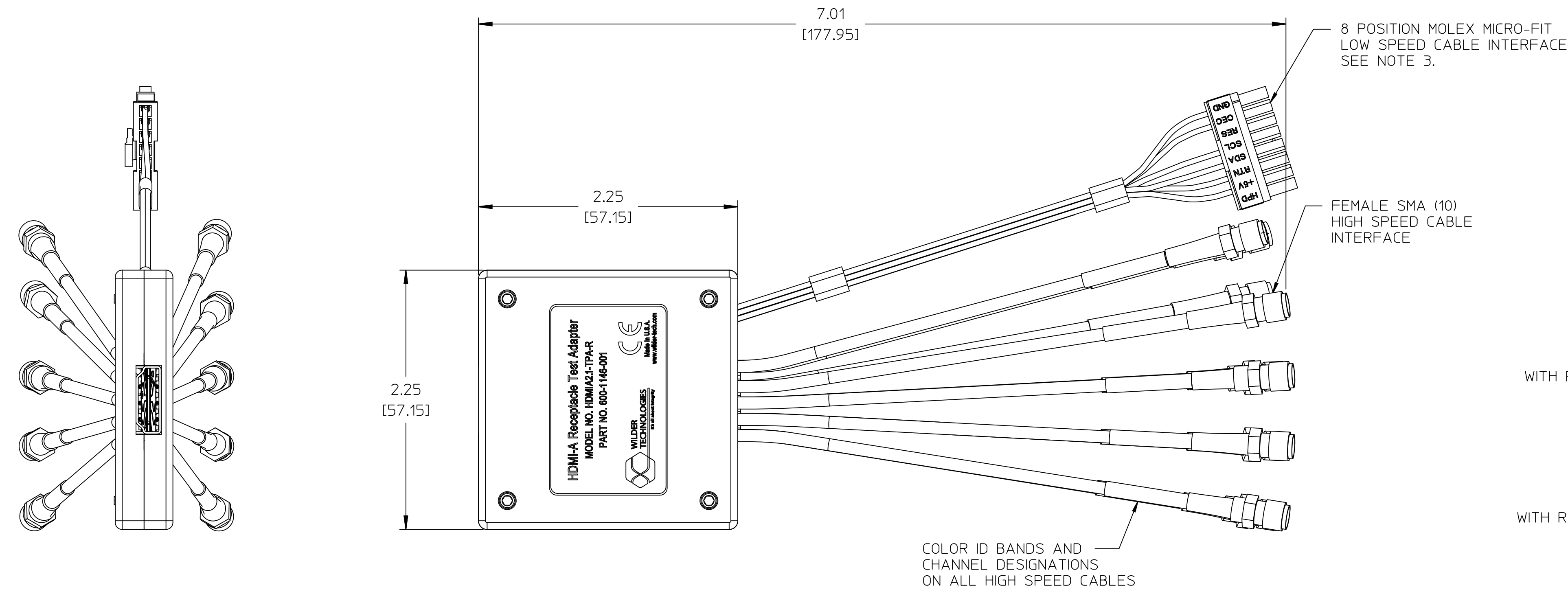

LABEL DESIGNATOR
DETAIL

1. INTERPRET DIMENSIONS AND TOLERANCES PER ANSI Y14.5.
 2. REFER TO THE USERS MANUAL FOR DETAILED MECHANICAL AND ELECTRICAL SPECIFICATIONS.
 3. THE LOW SPEED INTERFACE RECEPTACLE CONNECTOR HAS A MATING PLUG AND CONTACTS SUPPLIED TO ALLOW USERS TO CONNECT TO THIS ASSEMBLY.
- NOTE: UNLESS OTHERWISE SPECIFIED

RoHS COMPLIANT

UNLESS OTHERWISE SPECIFIED DIMENSIONS ARE: INCHES (METRIC)		WILDER TECHNOLOGIES 6101A East 18th St. Vancouver, WA 98661 Tel: 360-859-3041 Fax: 360-859-3105 www.wilder-tech.com	
.XXX + .005 + .127 +	.XX + .01 + .25 +	DRAWN BY: W. STANLEY	DATE: 3/23/2017
.X + .12 + .3 +	ANGLE + 1° + 1°	CHECKED BY:	DATE:
MATERIAL:		APPROVED BY:	
		DESCRIPTION:	
FINAL ASSY, HDMI-A 2.1 RECEPTACLE, HDMI-A2.1-TPA-R			
FINISH:	SIZE PART NUMBER:	REV	
	D 600-1146-001	A	
SCALE: 1:1		DO NOT SCALE DRAWING	SHEET 1 OF 2