

THIS DOCUMENT CONTAINS PROPRIETARY INFORMATION AND IS THE PROPERTY OF WILDER TECHNOLOGIES. THIS INFORMATION SHALL NOT BE REPRODUCED, TRANSFERRED TO OTHER DOCUMENTS, DISCLOSED TO OTHERS FOR MANUFACTURING OR ANY OTHER PURPOSE WITHOUT WRITTEN PERMISSION FROM WILDER TECHNOLOGIES.

REVISIONS				
REV	AUTH	DESCRIPTION	APVD DATE	CHK DATE
A	ECNXXXX	INITIAL RELEASE	WS	10/9/18

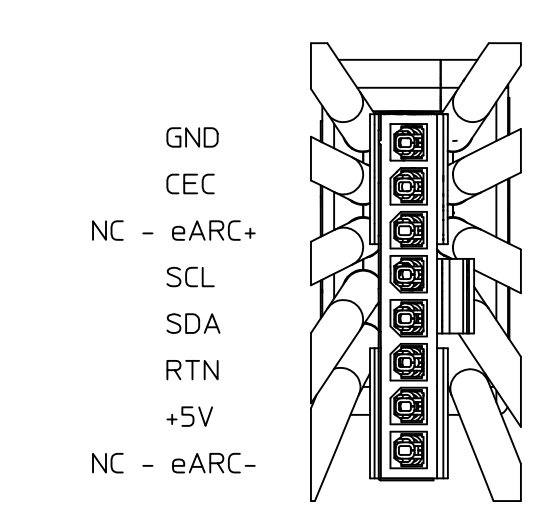

DETAIL B - SCALE 2:1
SCALE 2:1

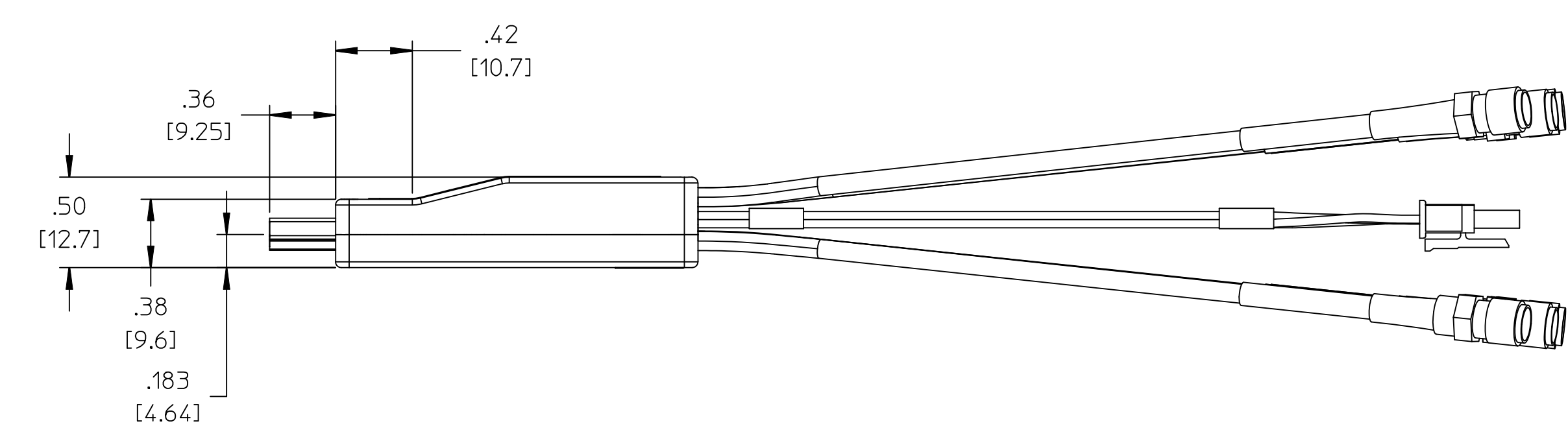
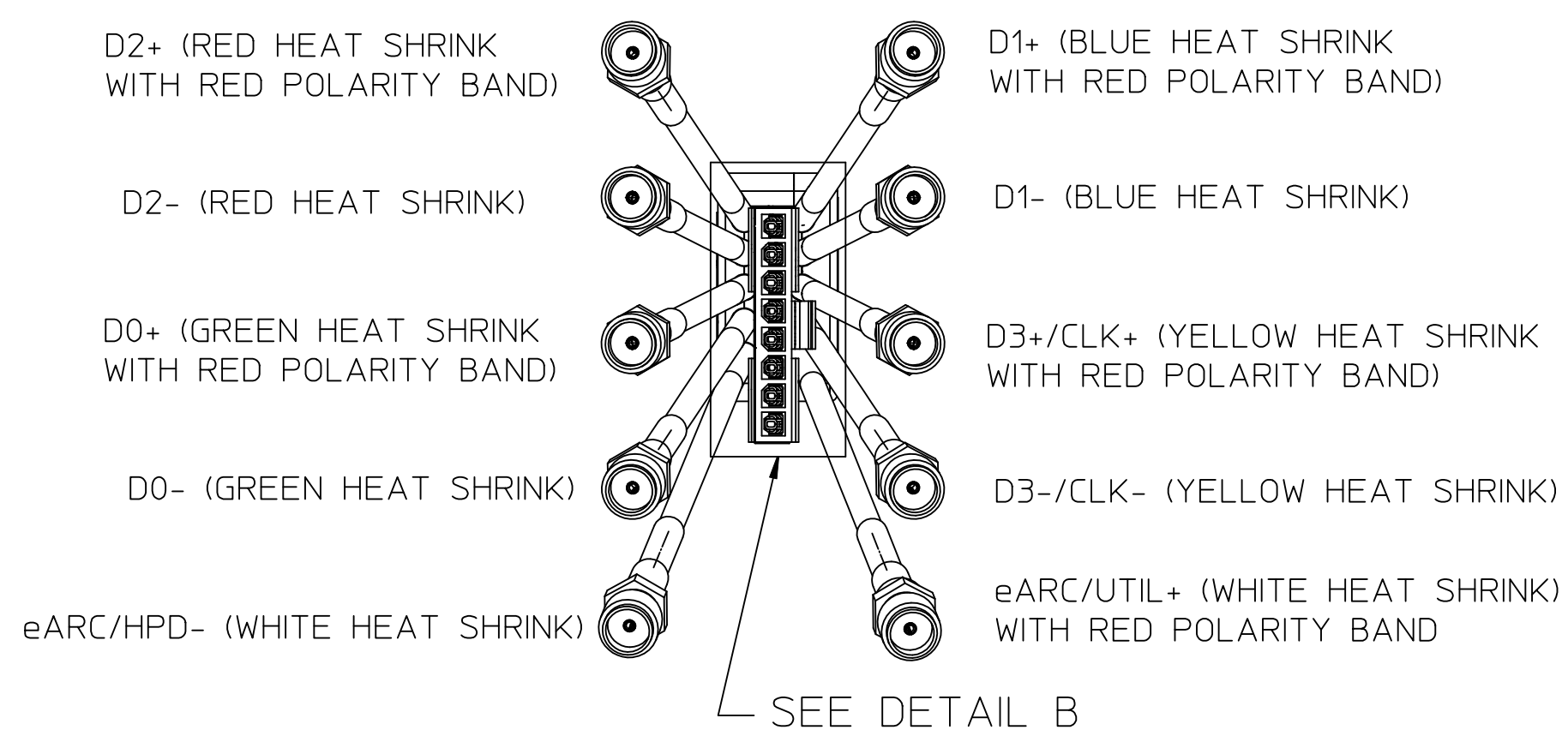
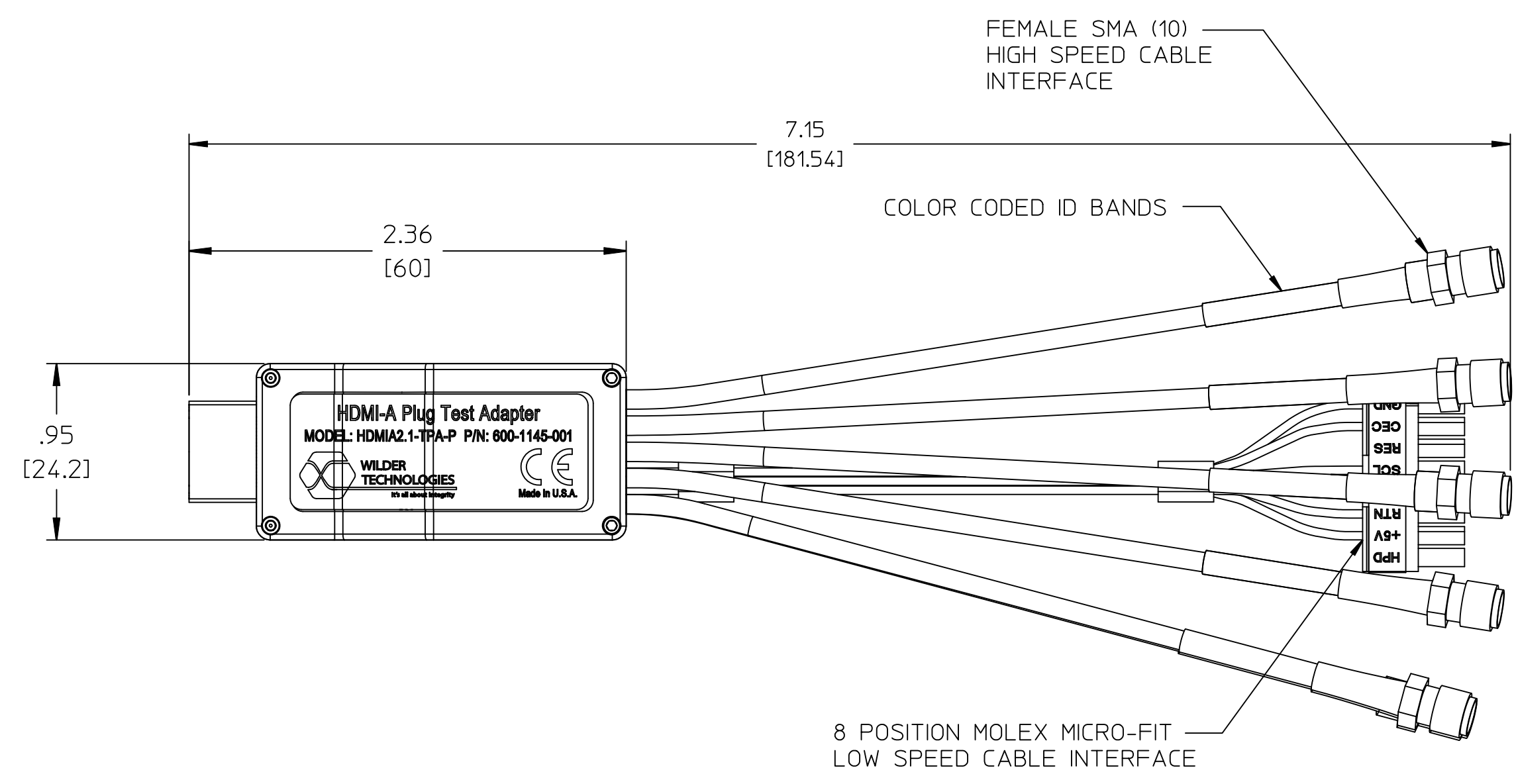
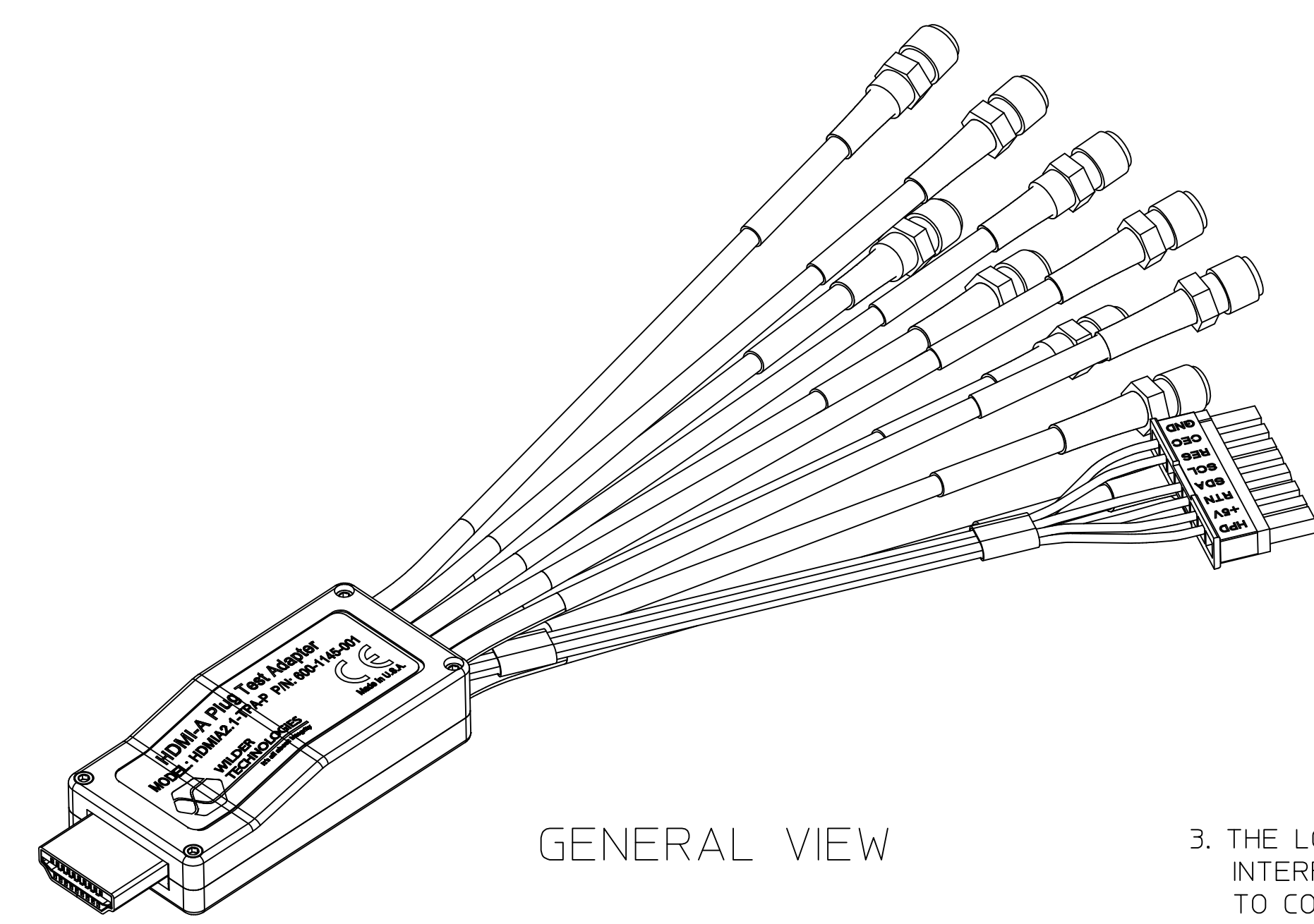

GENERAL VIEW

3. THE LOW SPEED INTERFACE CABLE ASSEMBLY HAS A SEPARATE INTERFACE PLUG AND CONTACTS SUPPLIED TO ALLOW USERS TO CONNECT TO THIS ASSEMBLY.
 2. REFER TO THE USERS MANUAL FOR DETAILED MECHANICAL AND ELECTRICAL SPECIFICATIONS.
 1. INTERPRET DIMENSIONS AND TOLERANCES PER ANSI Y14.5.
- NOTE: UNLESS OTHERWISE SPECIFIED

RoHS COMPLIANT 2011/65/EU

UNLESS OTHERWISE SPECIFIED DIMENSIONS ARE INCHES (METRIC)		WILDER TECHNOLOGIES 6101A East 18th St Vancouver, WA 98661 Tel: 360-859-3041 Fax: 360-859-3105 www.wilder-tech.com	
XXX ±	.005 ±	.127 ±	
XX ±	.01 ±	.25 ±	
X ±	.12 ±	3 ±	
ANGLE	1°	1°	
DRAWN BY: W.STANLEY		DATE: 10/9/18	
CHECKED BY:		DATE:	
APPROVED BY:		DATE:	
MATERIAL:		DESCRIPTION:	
SEE SEPARATE BILL OF MATERIAL		FINAL ASSEMBLY, HDMI2.1, NY PLUG HDMI2.1-TPA-P	
FINISH:	SIZE PART NUMBER:	REV	
NA	D 600-1145-001	A	
SCALE: 1:1		DO NOT SCALE DRAWING SHEET 1 OF 2	