

REVISIONS

REV	AUTH	DESCRIPTION	APVD DATE	CHK DATE
A	ECNXXXX	PRELIMINARY RELEASE		5/6/11

PLASTIC BASE PROVIDES PROTECTION FOR SECONDARY SIDE COMPONENTS

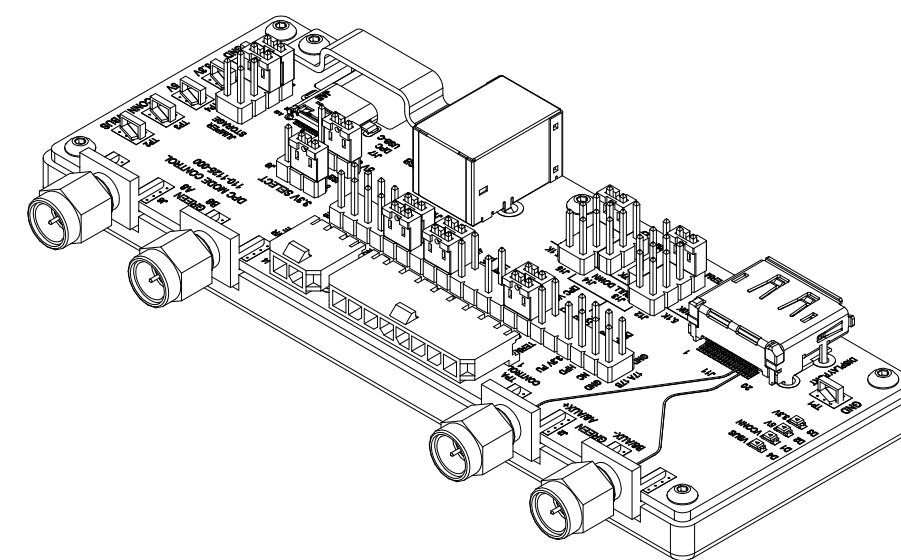
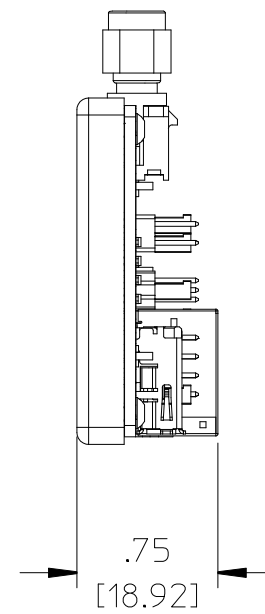
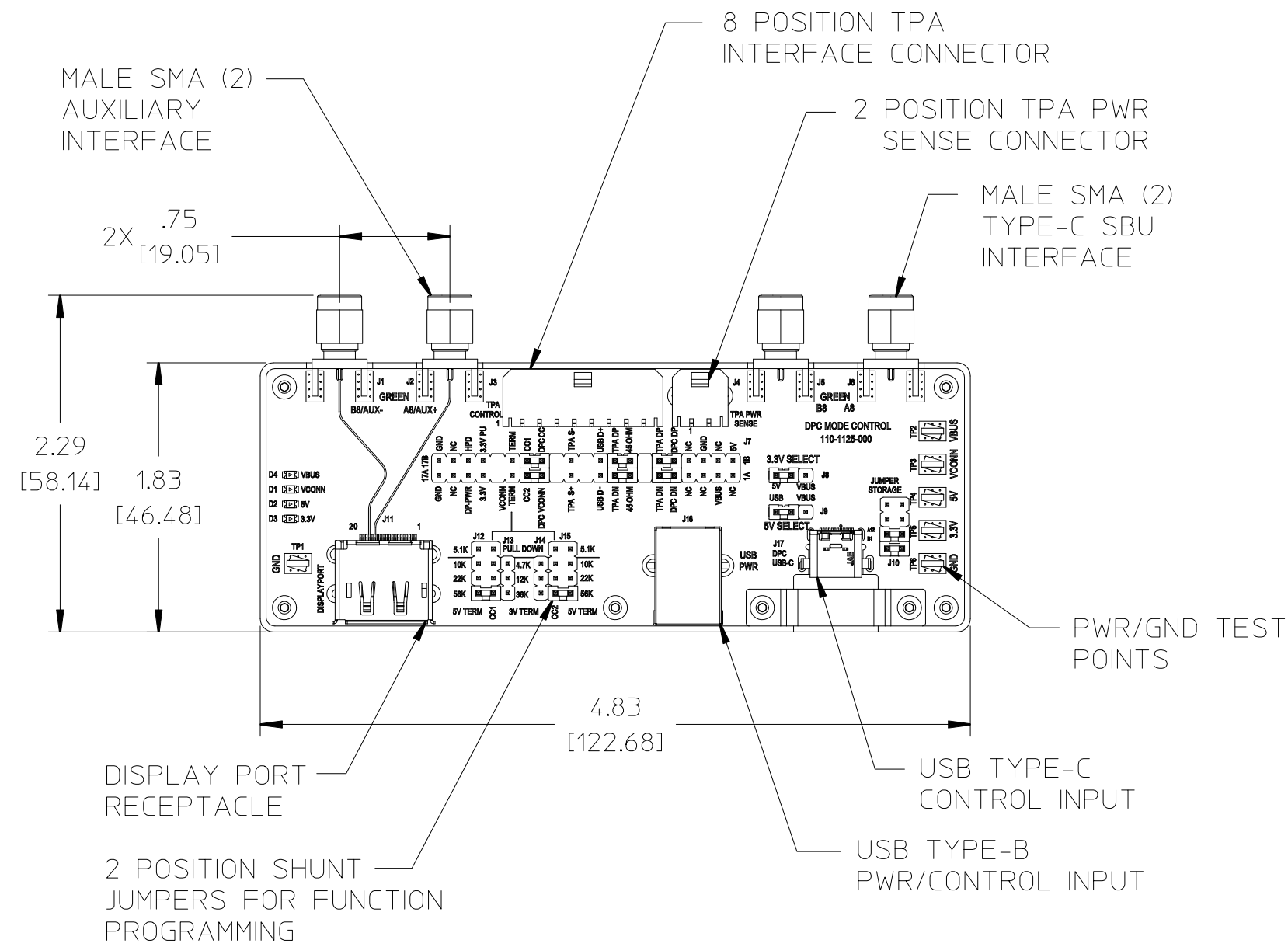
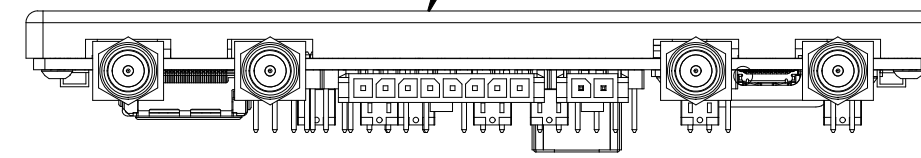

GENERAL VIEW

3. LEAD FREE PROCESSES USED, COMPLIES WITH EC DIRECTIVE 2002/95/EC (RoHS DIRECTIVE) RESTRICTIVE USE OF HAZARDOUS SUBSTANCES.

2. REFER TO THE USERS MANUAL FOR DETAILED MECHANICAL AND ELECTRICAL SPECIFICATIONS.

1. INTERPRET DIMENSIONS AND TOLERANCES PER ANSI Y14.5

NOTE: UNLESS OTHERWISE SPECIFIED

UNLESS OTHERWISE SPECIFIED DIMENSIONS ARE INCHES [METRIC] .XXX ± .005 ± .127 ± .XX ± .01 ± .25 ± .X ± .12 ± .3 ± ANGLE ± 1° 1°	 6101A East 18th St. Vancouver, WA 98661 Tel: 360-859-3041 Fax: 360-859-3105 www.wilder-tech.com	
	DRAWN BY: W. STANLEY	DATE: 8/25/2015
MATERIAL:	CHECKED BY:	DATE:
APPROVED BY:	DATE:	
DESCRIPTION: FINAL ASSEMBLY, ECB, DISPLAY PORT, TYPE-C MODE CONTROL BOARD, DPC-TPA-CB		
FINISH:	SIZE C	PART NUMBER: 600-1125-000
SCALE: 1:1	DO NOT SCALE DRAWING	SHEET 2 OF 2

REV A