

THIS DOCUMENT CONTAINS PROPRIETARY INFORMATION AND IS THE PROPERTY OF WILDER TECHNOLOGIES. THIS INFORMATION SHALL NOT BE REPRODUCED, TRANSFERRED TO OTHER DOCUMENTS, DISCLOSED TO OTHERS FOR MANUFACTURING OR ANY OTHER PURPOSE WITHOUT WRITTEN PERMISSION FROM WILDER TECHNOLOGIES.

REVISIONS				
REV	AUTH	DESCRIPTION	APVD DATE	CHK DATE
A	XXXX	INITIAL RELEASE	TD	3/14/2013

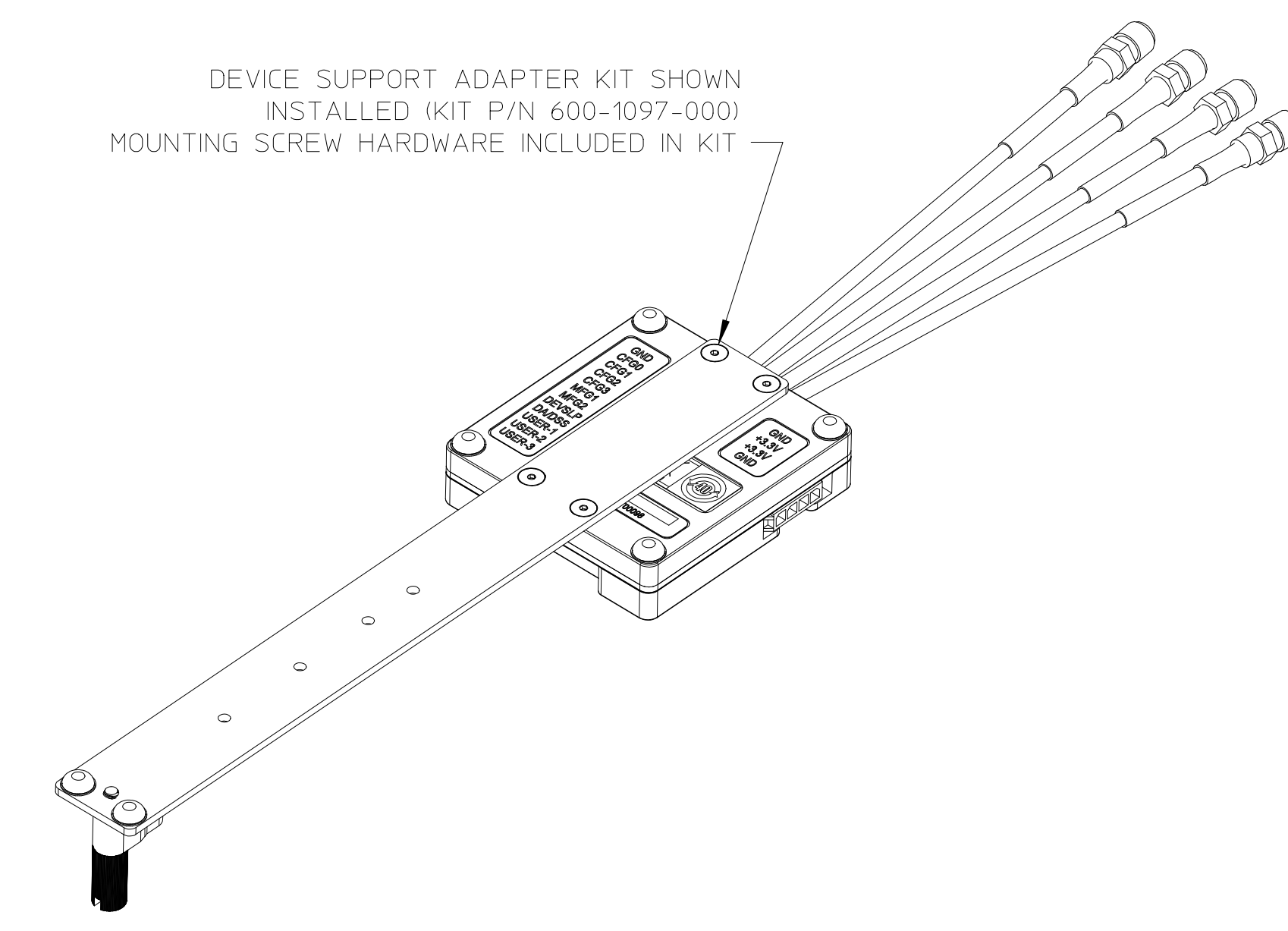
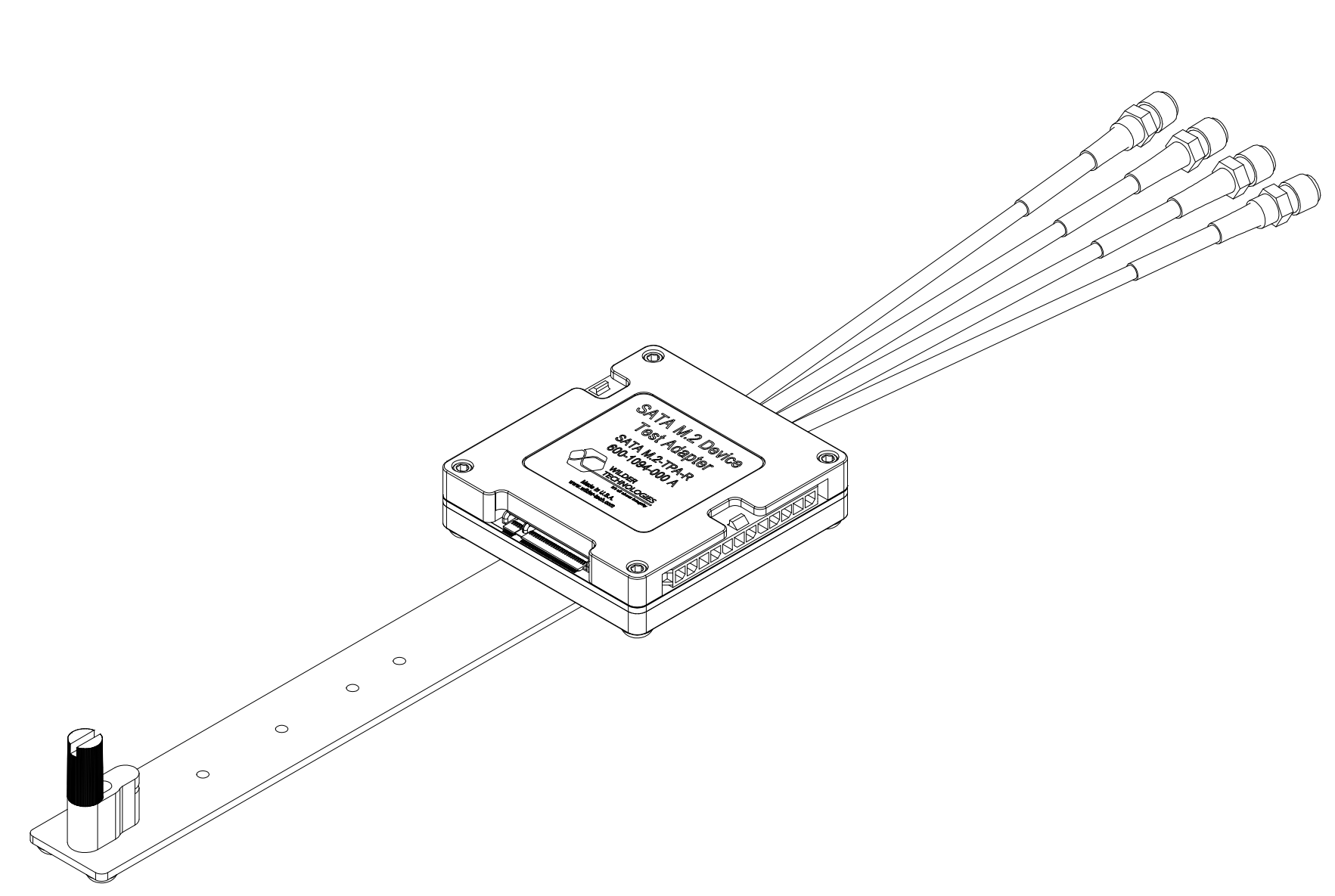
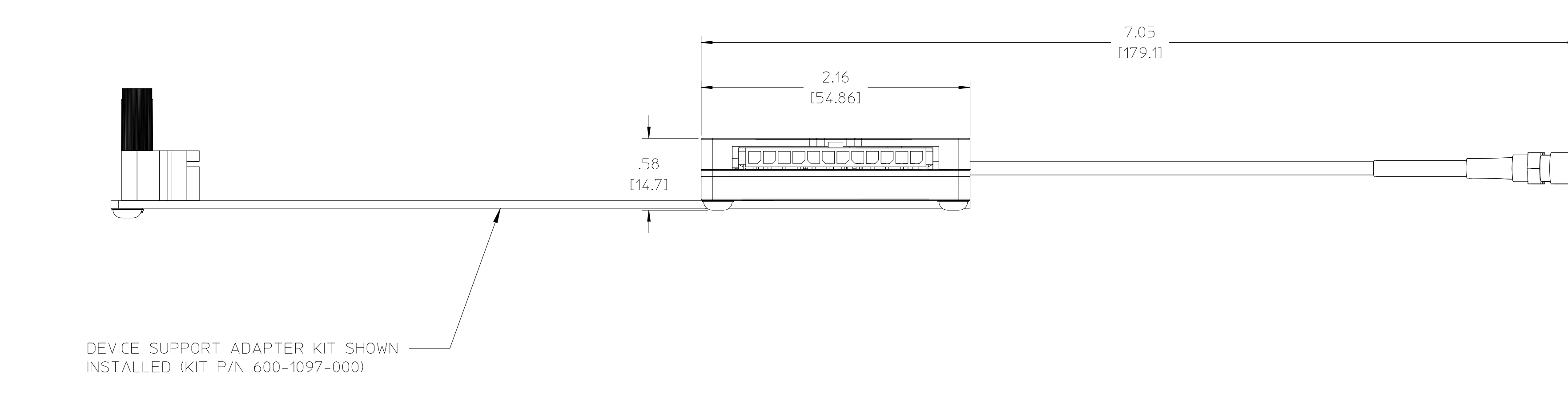
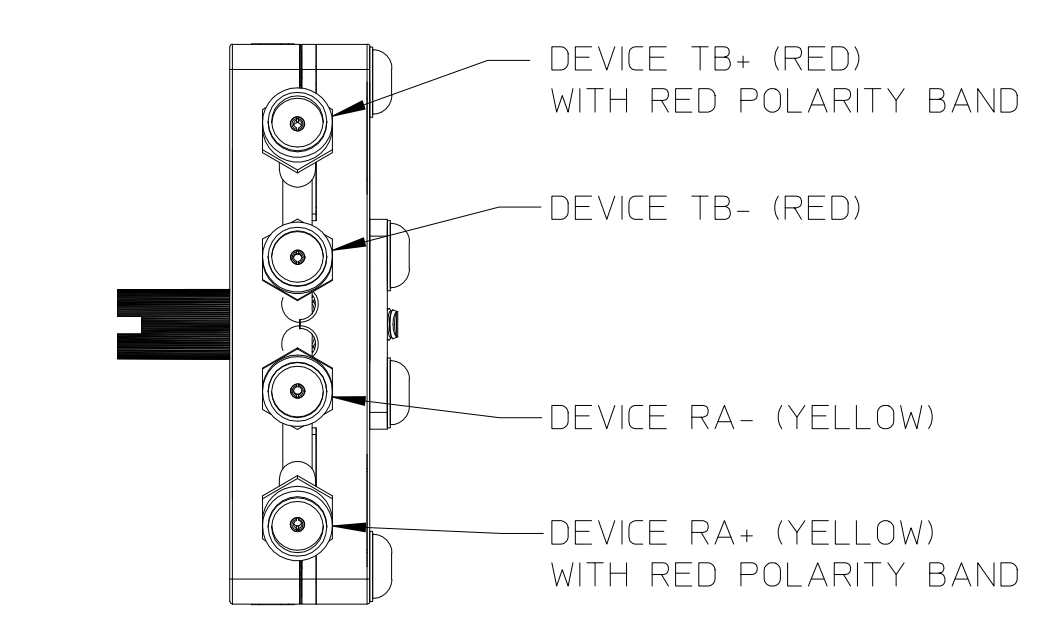
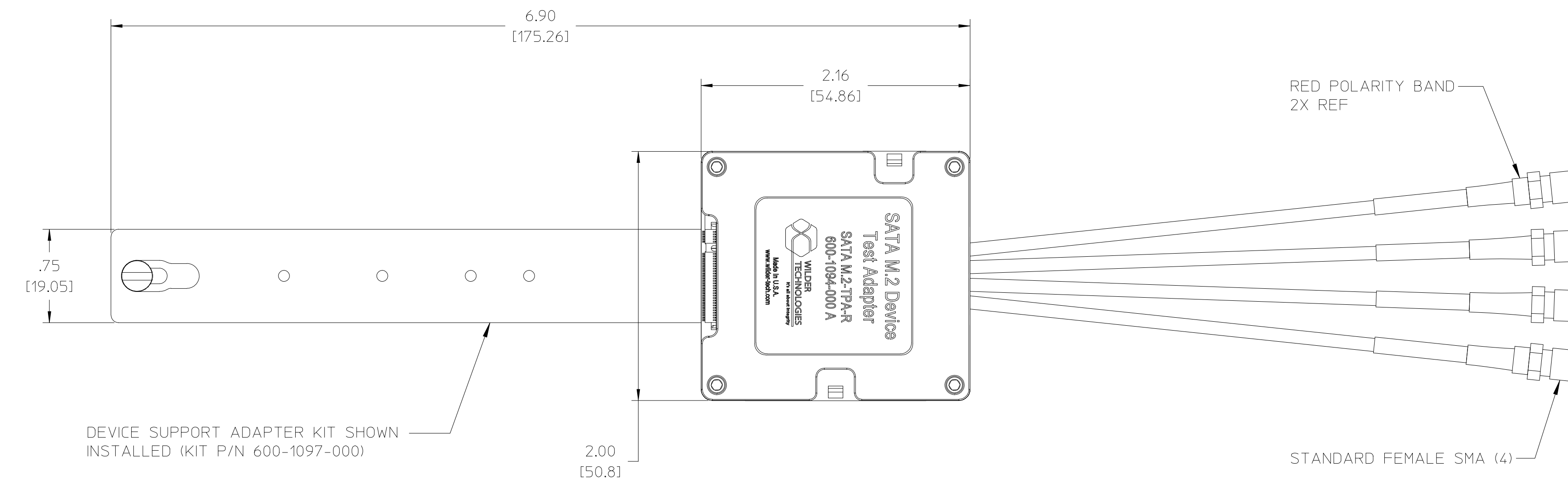

- NOTE: UNLESS OTHERWISE SPECIFIED
1. INTERPRET DIMENSIONS AND TOLERANCES PER ANSI Y14.5.
 2. REFER TO THE USERS MANUAL FOR DETAILED MECHANICAL AND ELECTRICAL SPECIFICATIONS.
 3. THIS TEST ADAPTER IS SUPPLIED WITH A MATING RECEPTACLE CONNECTOR AND CONTACTS FOR USER CONNECTION TO THE LOW-SPEED INTERFACE CONNECTOR.
 4. THIS TEST ADAPTER IS SUPPLIED WITH TWO TYPES OF PRE-ASSEMBLED POWER HARNESSES FOR USER INPUT POWER.

UNLESS OTHERWISE SPECIFIED DIMENSIONS ARE INCHES (METRIC)				6101A East 18th St. Vancouver, WA 98661 Tel: 360-859-3011 Fax: 360-859-3105 www.wilder-tech.com	
.XXX	.005 ± .127 ±	DRAWN BY:	T. DELUCCO	DATE:	3/14/2013
.XX	.01 ± .25 ±	CHECKED BY:		DATE:	
.X	.12 ± .3 ±	APPROVED BY:		DATE:	
ANGLE	1° ± 1°	MATERIAL:			
FINISH:		DESCRIPTION:			
		CUSTOMER REFERENCE DRAWING FINAL ASSEMBLY, SATA M.2 DEVICE TEST ADAPTER			
SIZE	PART NUMBER:	REV			
D	600-1094-000	A			
SCALE: 1:1	DO NOT SCALE DRAWING	SHEET 3 OF 3			