

REVISIONS

REV	AUTH	DESCRIPTION	APVD DATE	CHK DATE
A	XXXX	INITIAL RELEASE	TD	8/6/2010

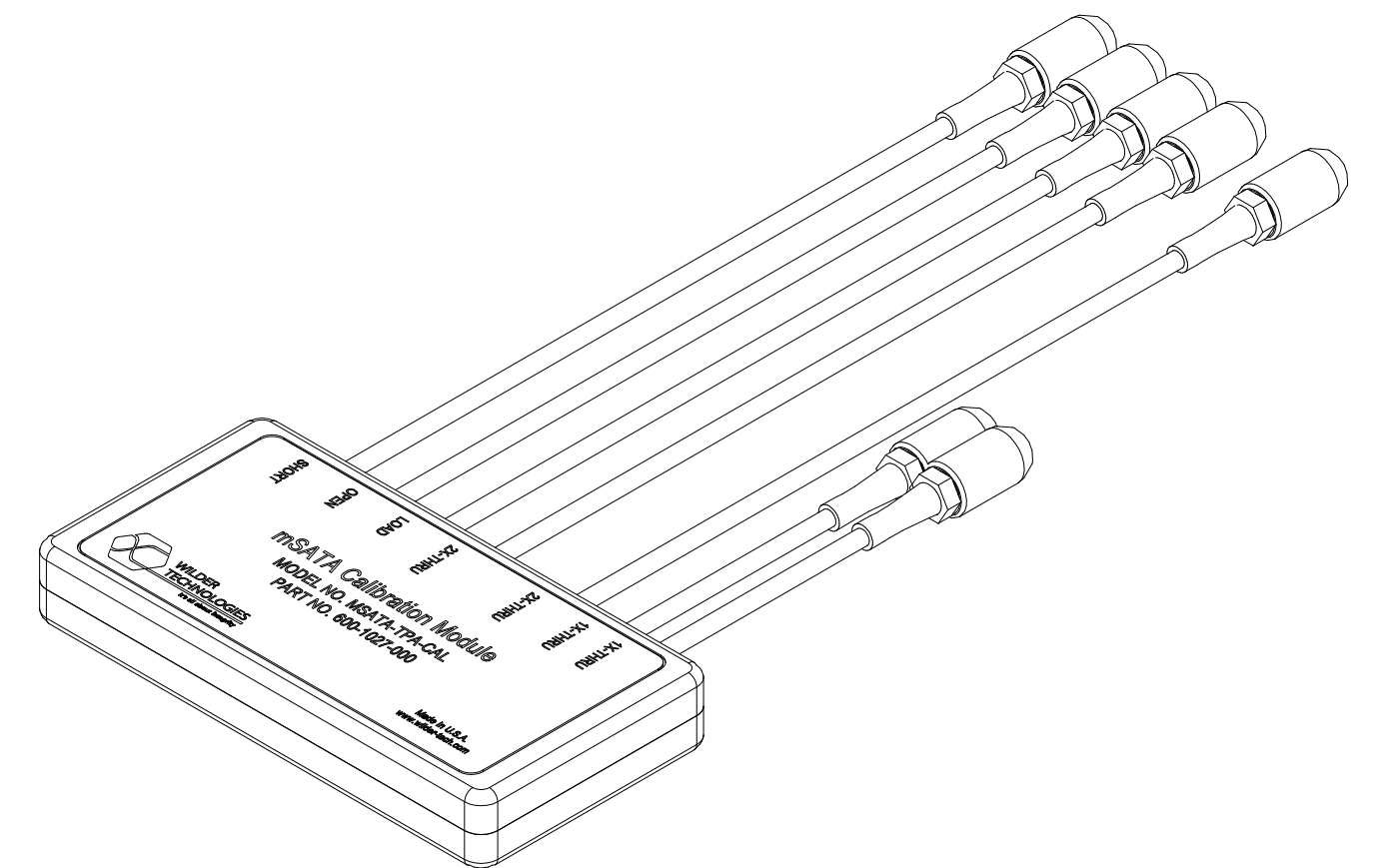
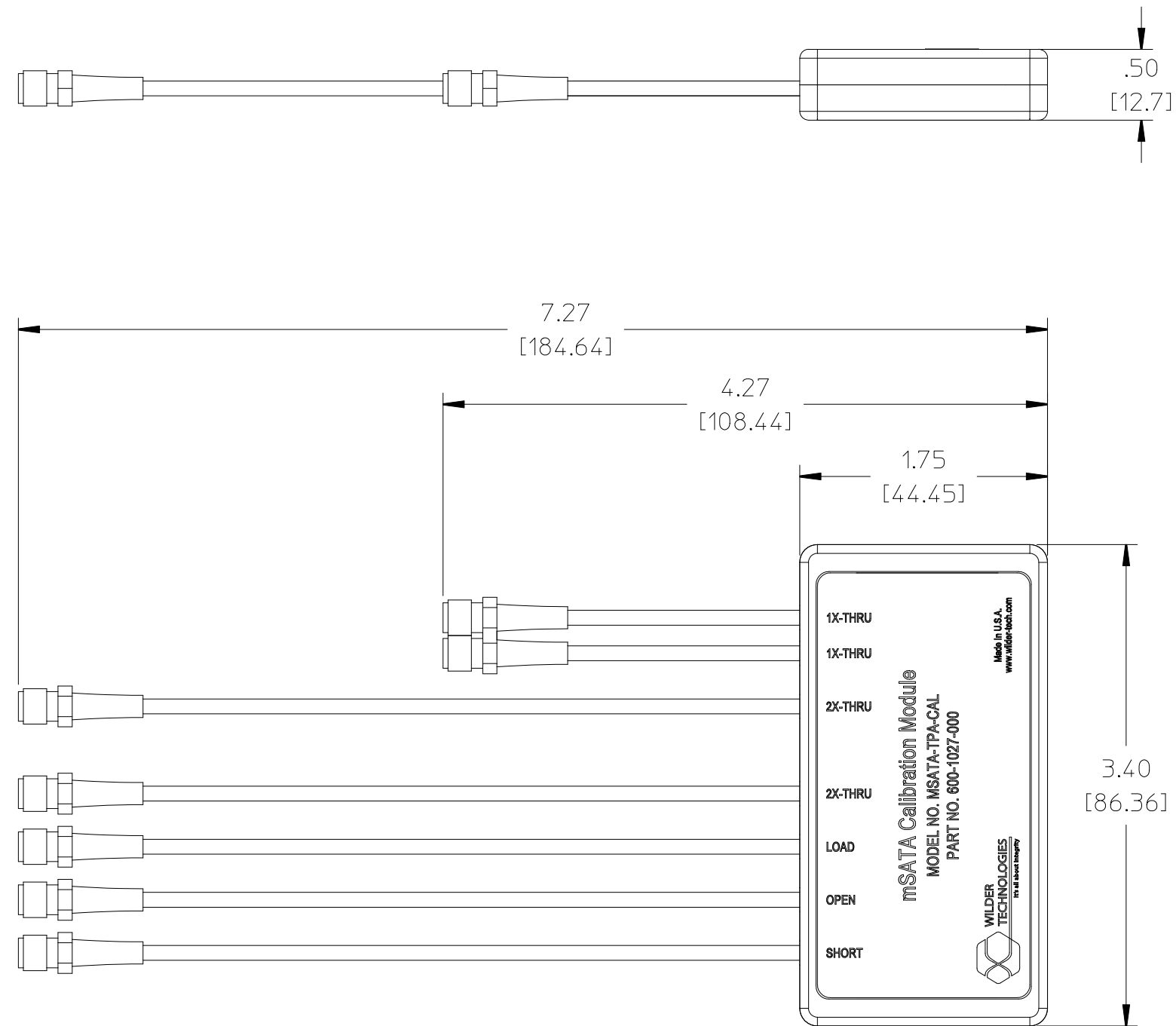

GENERAL VIEW

NOTE: UNLESS OTHERWISE SPECIFIED

1. REFER TO THE USERS MANUAL FOR DETAILED MECHANICAL AND ELECTRICAL SPECIFICATIONS.
2. INTERPRET DIMENSIONS AND TOLERANCES PER ANSI Y14.5.

UNLESS OTHERWISE SPECIFIED DIMENSIONS ARE INCHES (METRIC)		 WILDER TECHNOLOGIES <small>It's all about integrity</small>		6101A East 18th St. Vancouver, WA 98661 Tel: 360-859-3041 Fax: 360-859-3105 www.wilder-tech.com	
.XXX ±	.005 ±	.127 ±	DRAWN BY:	T. DELUCCO	DATE: 8/6/2010
.XX ±	.01 ±	.25 ±	CHECKED BY:		DATE:
.X ±	.12 ±	.3 ±	APPROVED BY:		DATE:
ANGLE ±	1°	1°	DESCRIPTION:		
			FINAL ASSEMBLY, mSATA CALIBRATION MSATA-TPA-C		
FINISH:	SIZE	PART NUMBER:	REV		
	C	600-1027-000	A		
SCALE: 1:1		DO NOT SCALE DRAWING		SHEET 2 OF 2	